

タダノ オールテレーンクレーン
GA - 1000N 型
(6段ブーム)
仕 様 書

キャリア FAUN RTF 101 - 4
スペック番号 GA-1000N-1-90101

株式会社 タダノ

管理番号 JA - 02

GA - 1000N 型 100 t オールテレークレーン

1. 主要諸元

クレーン

クレーン容量	11.7 mブーム	100,000 kg × 2.8 m (13本掛)
	15.4 mブーム	70,000 kg × 4.0 m (9本掛)
	19.2 mブーム	64,000 kg × 4.5 m (8本掛)
	22.9 mブーム	53,300 kg × 4.0 m (7本掛)
	26.7 mブーム	41,500 kg × 5.0 m (7本掛)
	30.4 mブーム	32,100 kg × 6.0 m (5本掛)
	34.2 mブーム	24,900 kg × 8.0 m (4本掛)
	37.9 mブーム	20,600 kg × 10.0 m (4本掛)
	41.7 mブーム	19,100 kg × 10.0 m (4本掛)
	45.4 mブーム	15,000 kg × 12.0 m (4本掛)
	49.2 mブーム	12,500 kg × 14.0 m (4本掛)
	52.0 mブーム	9,700 kg × 16.0 m (3本掛)
	9.0 mジブ	6,100 kg × 73° (1本掛)
	14.0 mジブ	3,500 kg × 73° (1本掛)
	19.0 mジブ	2,500 kg × 78° (1本掛)
最大地上揚程	ブーム	52.0 m
	ジブ	70.5 m
最大作業半径	ブーム	46.0 m
	ジブ	49.8 m
ブーム長さ		11.7 m ~ 52.0 m
ブーム伸縮長さ		40.3 m
ジブ長さ		9.0 m ~ 19.0 m
主巻ロープ巻上げ速度		高速: 140 m/min、低速: 70 m/min (4層)
主巻フック巻上げ速度		高速: 10.8 m/min、低速: 5.4 m/min (13本掛)
補巻ロープ巻上げ速度		高速: 140 m/min、低速: 70 m/min (4層)
補巻フック巻上げ速度		高速: 140 m/min、低速: 70 m/min (1本掛)
ブーム起伏角度		-1.7° ~ 81.5°
ブーム上げ速度		-1.7° ~ 81.5° / 55 s
旋回角度		360°連続
旋回速度		1.5 min ⁻¹ {rpm}
ワイヤロープ	主巻	径 22 mm × 長さ 263 m 非自転性ワイヤロープ
	補巻	径 22 mm × 長さ 150 m 非自転性ワイヤロープ

フック	100 t 吊 (13 本掛) 50 t 吊 (7 本掛) 8 t 吊 (1 本掛)
ブーム形式	箱型 6 段油圧伸縮式
ブーム伸縮装置	各段ピンロック方式 複動油圧シリンダ直押式 1 本 圧力補償付流量調整弁付
ジブ形式	ブーム横折曲格納式 3 段油圧同時伸縮式 オフセット 5° ~ 60° 油圧無段階傾斜式
シングルトップ 巻上装置	先端ブーム取付横折曲格納式 油圧モータ駆動遊星歯車減速式 自動ブレーキ シングルウインチ 2 基 圧力補償付流量調整弁付
ブーム起伏装置	複動油圧シリンダ直押式 1 本 圧力補償付流量調整弁付
旋回装置	油圧モータ駆動遊星歯車減速式 スイングベアリング式 手動スイッチ式ブレーキ 旋回フリー・ロック切換式
アウトリガ	全油圧式 H 型 スライドジャッキ各個操作装置付 最大張出幅 7.2m 中間張出幅 6.36m、4.9m、4.0m スライド格納式フロート
作業時最大路面荷重	80 t
動力取出方式	上部専用エンジン 名 称 三菱 6D16-TE1 形 式 水冷 4 サイクル 直列 6 気筒 直接噴射式ディーゼルエンジン 総排気量 7.54 L 最高出力 126 kW{171 PS} / 1,830 min ⁻¹ 最大トルク 687 N·m{70.0 kgf·m} / 1,600 min ⁻¹
油圧ポンプ 作動油タンク容量	高圧可変°スポン° 2 連 + 高圧°ポン° 2 連 1010 L

安 全 装 置

過負荷防止装置（AML）
作業範囲制限機能付
フック移動量表示機能付
アウトリガ張出幅自動検出装置（個別検出式）
ウエイト組合せ自動検出装置
旋回範囲制御装置
旋回自動停止機能付
ブーム起伏緩停止機能付
巻過防止装置
捨巻確保装置
水準器
玉掛けロープはずれ止め
乱巻防止装置
ウインチドラムロック装置
旋回ロック装置
油圧安全弁
伸縮シリンダ油圧ロック装置
起伏シリンダ油圧ロック装置
ジャッキシリンダ油圧ロック装置

付 属 装 置

カウンタウエイト脱着装置
ジブ張出装置
ブーム起伏微速モード設定装置
旋回微速モード設定装置
旋回体脱着装置（脱着リング）
AML外部表示灯
オイルクーラ
クレーンキャブエアコン
FM付ラジオ
ホット&クールボックス
ランチテーブル
ドラム視認モニター
旋回音声警報装置

オ プ シ ョ ン

TVチューナー
旋回体脱着装置（脱着リフター）
拡声器

キャリヤ			
メーカ名			F A U N G m b H
キャリヤ型式			R T F 1 0 1 - 4
エンジン	型 式		OM501LA (ベンツ製) 水冷4サイクルV型6気筒直接噴射式 インタークーラ付ターボ ディーゼルエンジン
	総排気量		11.946 L
	最高出力		315 kW{428 PS} / 1,800 rpm
	最大トルク		2000N・m{204 kgf・m} / 1,080 rpm
変速機形式			フルオートマチック 前進6段、後退1段 副変速機付
クラッチ形式			トルクコンバータ付 自動ロックアップ機構付
駆動方式			8 × 6
車軸形式 (全軸)			全浮動式
懸架方式 (全軸)			ハイドロニューマチックサスペンション サスペンションストローク +151 mm -125 mm
ステアリング	形 式		左ハンドル 全油圧式パワーステアリング 2系統式 非常用パワーステアリング
	モ ー ド		ノーマル (前4輪) クランプ (8輪) ク ラ ブ (8輪) リヤステ (後4輪)
ブレーキ	主ブレーキ		空気式全輪制動 2系統式
	駐車ブレーキ		2・3・4軸 (6輪) 制動 スプリング式
	非常ブレーキ		駐車ブレーキと兼用
	補助ブレーキ		電気式リターダ
バッテリー			12V - 170Ah × 2個 (24V)
燃料タンク容量			400 L
乗車定員			2人
タイヤ			445/95R25 177E ROAD (全輪)
ホイール			11.00 - 25 (全輪)
付属装置			カーエアコン FM付ラジオ マッドガード 集中給油装置 仮眠用ベッド バックモニタカメラ

走行時寸法（台車のみ）

全	長	10,815 mm
全	幅	2,780 mm
全	高	3,075 mm
軸	距	1,690 mm + 2,305 mm + 1,700 mm = 5,695 mm
輪	距	2,310 mm

重 量（台車のみ）

車 両 総 重 量		24,630 kg（人員2名）
	前 軸 重	13,180 kg
	後 軸 重	11,450 kg

走行性能

最 高 速 度		63 km/h
登 坂 能 力	（tan ）	1.13
最 小 回 転 半 径	4 輪ステアリング	11.2m
	8 輪ステアリング	7.0m

- （注意）1．本機は、公道を走行する場合には、旋回体を別送し、台車のみで走行しなければなりません。
- 2．道路法による基本通行条件のA条件適合車です。

2. 定格総荷重表

[ブーム]

A性能

{
 カウンタウエイト 21 t
 アウトリガ張出幅 7.2 m

単位：t

性能番号	1	2	3	4	5	6	7	8	9	10	11
ブーム長さ	11.7m	15.4m	19.2m	22.9m	26.7m	30.4m	34.2m	37.9m	41.7m	45.4m	49.2m
作業半径 (m)											
2.8	100.0	31.3	23.4	25.9							
3.0	96.2	30.5	22.6	25.2							
3.5	86.7	28.8	21.0	23.5							
4.0	75.5	27.2	19.6	22.1	22.5						
4.5	66.7	25.7	18.4	20.8	20.9	22.5					
5.0	59.6	24.5	17.3	19.7	19.6	21.5					
6.0	48.7	22.3	15.4	17.7	17.3	19.1	18.6				
7.0	40.8	20.5	13.9	16.1	15.5	17.2	18.6	16.2	14.4		
8.0	34.8	19.0	12.7	14.8	14.0	15.7	16.8	16.2	14.4	13.3	
9.0	30.1	17.7	11.6	13.6	12.8	14.3	15.3	16.2	14.4	13.3	12.5
10.0		16.7	10.7	12.6	11.7	13.2	13.9	15.2	14.4	13.3	12.5
12.0		15.1	9.3	11.0	10.0	11.3	11.6	12.9	12.8	13.3	12.5
14.0			8.2	9.8	8.6	9.9	10.0	11.1	10.9	11.9	12.5
16.0			7.3	8.8	7.6	8.8	8.6	9.7	9.4	10.3	11.0
18.0				8.0	6.8	7.8	7.6	8.5	8.2	9.0	9.7
20.0				7.4	6.1	7.1	6.7	7.6	7.2	8.0	8.6
22.0					5.5	6.4	6.0	6.8	6.4	7.1	7.7
24.0					5.1	5.9	5.4	6.1	5.7	6.4	7.0
26.0						5.5	4.9	5.6	5.1	5.8	5.9
28.0						5.1	4.4	5.1	4.6	5.2	5.0
30.0							4.0	4.7	4.1	4.7	4.3
32.0								4.3	3.8	4.0	3.7
34.0								4.0	3.4	3.5	3.1
36.0									3.1	3.0	2.6
38.0									2.8	2.6	2.2
40.0										2.2	1.8
42.0										1.9	1.5
44.0											1.2
46.0											1.0
ピン無最大荷重	42.0	31.3	23.4	25.9	22.5	22.5	18.6	16.2	14.4	13.3	12.5
(°)	0~81.5	0~81.5	0~81.5	0~81.5	0~81.5	0~81.5	0~81.5	0~81.5	0~81.5	0~81.5	0~81.5
各ブーム段の伸長状態 (%)											
2段目ブーム	0	0	0	0	0	0	0	0	0	47	93
3段目ブーム	0	0	0	0	0	0	0	47	93	93	93
4段目ブーム	0	0	0	0	0	47	93	93	93	93	93
5段目ブーム	0	0	0	47	93	93	93	93	93	93	93
6段目ブーム	0	47	93	93	93	93	93	93	93	93	93
ワイヤ掛数	13	4	4	4	4	4	4	4	4	4	4

[ブーム]

A性能

カウンタウエイト 21 t
アウトリガ張出幅 7.2 m

単位: t

性能番号	12	13	14	15	16	17	18	19	20	21	22	23	24	25	26	27	28
ブーム長さ	19.2m	22.9m	26.7m	30.4m	34.2m	37.9m	41.7m	41.7m	45.4m	52.0m	15.4m	19.2m	22.9m	26.7m	22.9m	26.7m	30.4m
作業半径 (m)																	
2.8	32.0	32.0									70.0	64.0	53.3		35.0		
3.0	32.0	32.0									70.0	64.0	53.3		35.0		
3.5	32.0	32.0									70.0	64.0	53.3		35.0	35.0	
4.0	30.5	32.0	32.0								70.0	64.0	53.3	41.5	35.0	35.0	
4.5	29.1	31.7	32.0	29.0							67.2	64.0	52.5	41.5	35.0	35.0	32.1
5.0	27.8	30.4	32.0	29.0							60.0	59.9	49.3	41.5	35.0	35.0	32.1
6.0	25.5	28.1	30.2	29.0	24.9	20.6					49.1	49.0	43.8	38.0	35.0	35.0	32.1
7.0	23.6	26.1	28.2	29.0	24.9	20.6	19.1	16.5			41.2	41.1	39.4	33.9	35.0	35.0	31.6
8.0	21.9	24.4	26.5	28.2	24.9	20.6	19.1	16.5	15.0		35.2	35.0	35.4	30.6	35.0	35.0	28.5
9.0	20.5	22.9	24.9	26.7	24.3	20.6	19.1	16.5	15.0		30.4	30.3	30.7	27.8	32.2	31.9	25.9
10.0	19.3	21.6	23.6	25.3	22.2	20.6	19.1	16.5	15.0	9.7	26.6	26.5	26.8	25.4	28.4	28.0	23.7
12.0	17.3	19.4	21.3	22.8	18.9	17.5	16.6	14.6	15.0	9.7	20.5	20.4	20.7	20.4	22.4	22.0	20.1
14.0	15.9	17.7	18.1	17.7	16.3	15.0	14.2	12.5	13.5	9.7		15.4	15.7	15.4	17.2	16.9	16.4
16.0	14.3	14.6	14.5	14.1	13.6	13.1	12.4	10.9	11.8	9.7		12.0	12.3	11.9	13.7	13.4	12.9
18.0		12.0	11.9	11.5	11.1	11.0	10.8	9.5	10.4	8.9			9.7	9.4	11.1	10.8	10.4
20.0		10.0	9.9	9.5	9.1	9.1	9.2	8.4	9.1	7.9			7.8	7.5	9.2	8.8	8.4
22.0			8.3	8.0	7.5	7.5	7.7	7.5	7.9	7.1				6.0		7.3	6.9
24.0			7.1	6.7	6.3	6.3	6.4	6.7	6.7	6.3				4.8		6.1	5.7
26.0				5.7	5.2	5.2	5.4	6.0	5.6	5.7							4.7
28.0				4.9	4.4	4.4	4.5	5.1	4.7	5.1							3.9
30.0					3.7	3.6	3.8	4.4	4.0	4.4							
32.0						3.0	3.2	3.7	3.4	3.8							
34.0						2.5	2.6	3.2	2.8	3.2							
36.0							2.2	2.7	2.4	2.7							
38.0								1.8	2.3	2.0	2.3						
40.0										1.6	1.9						
42.0										1.3	1.6						
44.0											1.3						
46.0											1.0						
ピン無最大荷重	32.0	32.0	32.0	29.0	24.9	20.6	19.1	16.5	15.0	9.7	36.0	34.0	33.0	26.0	33.0	32.0	26.0
(°)	0~81.5	0~81.5	0~81.5	0~81.5	0~81.5	0~81.5	0~81.5	0~81.5	0~81.5	18~81.5	0~81.5	0~81.5	0~81.5	0~81.5	0~81.5	0~81.5	0~81.5
各ブーム段の伸長状態 (%)																	
2段目ブーム	0	0	0	47	93	93	93	47	93	100	0	47	47	93	0	47	93
3段目ブーム	0	0	47	47	47	93	93	93	93	100	47	47	93	93	47	47	47
4段目ブーム	0	47	47	47	47	47	93	93	93	100	0	0	0	0	47	47	47
5段目ブーム	47	47	47	47	47	47	47	93	93	100	0	0	0	0	47	47	47
6段目ブーム	47	47	47	47	47	47	47	47	47	100	0	0	0	0	0	0	0
ワイヤ掛数	4	4	4	4	4	4	4	4	4	3	9	8	7	7	5	5	5

[ブーム]

B性能

カウンタウエイト 16 t
アウトリガ張出幅 7.2 m

単位：t

性能番号	1	2	3	4	5	6	7	8	9	10	11
ブーム長さ	11.7m	15.4m	19.2m	22.9m	26.7m	30.4m	34.2m	37.9m	41.7m	45.4m	49.2m
作業半径 (m)											
2.8	100.0	31.3	23.4	25.9							
3.0	96.2	30.5	22.6	25.2							
3.5	83.0	28.8	21.0	23.5							
4.0	72.3	27.2	19.6	22.1	22.5						
4.5	63.8	25.7	18.4	20.8	20.9	22.5					
5.0	56.9	24.5	17.3	19.7	19.6	21.5					
6.0	46.5	22.3	15.4	17.7	17.3	19.1	18.6				
7.0	38.8	20.5	13.9	16.1	15.5	17.2	18.6	16.2	14.4		
8.0	33.1	19.0	12.7	14.8	14.0	15.7	16.8	16.2	14.4	13.3	
9.0	28.5	17.7	11.6	13.6	12.8	14.3	15.3	16.2	14.4	13.3	12.5
10.0		16.7	10.7	12.6	11.7	13.2	13.9	15.2	14.4	13.3	12.5
12.0		15.1	9.3	11.0	10.0	11.3	11.6	12.9	12.8	13.3	12.5
14.0			8.2	9.8	8.6	9.9	10.0	11.1	10.9	11.9	12.5
16.0			7.3	8.8	7.6	8.8	8.6	9.7	9.4	10.3	11.0
18.0				8.0	6.8	7.8	7.6	8.5	8.2	9.0	9.7
20.0				7.4	6.1	7.1	6.7	7.6	7.2	8.0	8.4
22.0					5.5	6.4	6.0	6.8	6.4	7.1	6.9
24.0					5.1	5.9	5.4	6.1	5.7	6.2	5.8
26.0						5.5	4.9	5.6	5.1	5.2	4.9
28.0							5.1	4.4	4.9	4.4	4.1
30.0								4.0	4.2	4.0	3.4
32.0									3.7	3.4	2.8
34.0									3.2	2.9	2.3
36.0										2.5	1.9
38.0										2.1	1.5
40.0											1.6
42.0											1.3
ピン無最大荷重	42.0	31.3	23.4	25.9	22.5	22.5	18.6	16.2	14.4	13.3	12.5
(°)	0~81.5	0~81.5	0~81.5	0~81.5	0~81.5	0~81.5	0~81.5	0~81.5	0~81.5	0~81.5	23~81.5
各ブーム段の伸長状態 (%)											
2段目ブーム	0	0	0	0	0	0	0	0	0	47	93
3段目ブーム	0	0	0	0	0	0	0	47	93	93	93
4段目ブーム	0	0	0	0	0	47	93	93	93	93	93
5段目ブーム	0	0	0	47	93	93	93	93	93	93	93
6段目ブーム	0	47	93	93	93	93	93	93	93	93	93
ワザ掛数	13	4	4	4	4	4	4	4	4	4	4

[ブ - ム]

B性能

〔カウンタウエイト 16 t〕
〔アウトリガ張出幅 7.2 m〕

単位：t

性能番号	12	13	14	15	16	17	18	19	20	21	22	23	24	25	26	27	28
ブーム長さ	19.2m	22.9m	26.7m	30.4m	34.2m	37.9m	41.7m	41.7m	45.4m	52.0m	15.4m	19.2m	22.9m	26.7m	22.9m	26.7m	30.4m
作業半径 (m)																	
2.8	32.0	32.0									70.0	64.0	53.3		35.0		
3.0	32.0	32.0									70.0	64.0	53.3		35.0		
3.5	32.0	32.0									70.0	64.0	53.3		35.0	35.0	
4.0	30.5	32.0	32.0								70.0	64.0	53.3	41.5	35.0	35.0	
4.5	29.1	31.7	32.0	29.0							64.3	64.0	52.5	41.5	35.0	35.0	32.1
5.0	27.8	30.4	32.0	29.0							57.4	57.2	49.3	41.5	35.0	35.0	32.1
6.0	25.5	28.1	30.2	29.0	24.9	20.6					46.9	46.8	43.8	38.0	35.0	35.0	32.1
7.0	23.6	26.1	28.2	29.0	24.9	20.6	19.1	16.5			39.3	39.1	39.4	33.9	35.0	35.0	31.6
8.0	21.9	24.4	26.5	28.2	24.9	20.6	19.1	16.5	15.0		33.5	33.4	33.7	30.6	35.0	34.9	28.5
9.0	20.5	22.9	24.9	26.7	24.3	20.6	19.1	16.5	15.0		28.9	28.8	29.1	27.8	30.7	30.3	25.9
10.0	19.3	21.6	23.6	25.3	22.2	20.6	19.1	16.5	15.0	9.7	25.0	24.8	25.2	24.9	27.0	26.6	23.7
12.0	17.3	19.4	20.6	20.1	18.9	17.5	16.6	14.6	15.0	9.7	17.8	17.7	18.0	17.7	19.7	19.3	18.8
14.0	15.7	16.0	15.8	15.4	15.0	15.0	14.2	12.5	13.5	9.7		13.2	13.5	13.2	15.0	14.7	14.2
16.0	12.4	12.7	12.6	12.2	11.8	11.7	11.9	10.9	11.8	9.7		10.1	10.4	10.1	11.8	11.5	11.0
18.0		10.4	10.2	9.9	9.4	9.4	9.6	9.5	9.8	8.9			8.1	7.8	9.5	9.2	8.7
20.0		8.6	8.4	8.1	7.6	7.6	7.8	8.4	8.0	7.9			6.4	6.1	7.7	7.4	7.0
22.0			7.0	6.7	6.2	6.2	6.4	7.0	6.6	7.1				4.7		6.0	5.6
24.0			5.9	5.5	5.1	5.1	5.2	5.9	5.5	5.9				3.7		4.9	4.5
26.0				4.6	4.2	4.2	4.3	4.9	4.6	5.0							3.6
28.0				3.9	3.4	3.4	3.5	4.1	3.8	4.2							2.9
30.0					2.8	2.7	2.9	3.5	3.1	3.5							
32.0						2.2	2.3	2.9	2.5	2.9							
34.0						1.7	1.8	2.4	2.1	2.4							
36.0							1.4	2.0	1.6	2.0							
38.0							1.1	1.6	1.3	1.6							
40.0									0.9	1.3							
42.0										1.0							
ピン無最大荷重	32.0	32.0	32.0	29.0	24.9	20.6	19.1	16.5	15.0	9.7	36.0	34.0	33.0	26.0	33.0	32.0	26.0
(°)	0~81.5	0~81.5	0~81.5	0~81.5	0~81.5	0~81.5	2~81.5	0~81.5	20~81.5	30~81.5	0~81.5	0~81.5	0~81.5	0~81.5	0~81.5	0~81.5	0~81.5
各ブーム段の伸長状態 (%)																	
2段目ブーム	0	0	0	47	93	93	93	47	93	100	0	47	47	93	0	47	93
3段目ブーム	0	0	47	47	47	93	93	93	93	100	47	47	93	93	47	47	47
4段目ブーム	0	47	47	47	47	47	93	93	93	100	0	0	0	0	47	47	47
5段目ブーム	47	47	47	47	47	47	47	93	93	100	0	0	0	0	47	47	47
6段目ブーム	47	47	47	47	47	47	47	47	47	100	0	0	0	0	0	0	0
ワイヤ掛数	4	4	4	4	4	4	4	4	4	3	9	8	7	7	5	5	5

[ブーム]

C性能

カウンタウエイト 21 t
アウトリガ張出幅 6.36 m

単位：t

性能番号	1	2	3	4	5	6	7	8	9	10	11
ブーム長さ	11.7m	15.4m	19.2m	22.9m	26.7m	30.4m	34.2m	37.9m	41.7m	45.4m	49.2m
作業半径 (m)											
2.8	85.1	31.3	23.4	25.9							
3.0	81.6	30.5	22.6	25.2							
3.5	73.8	28.8	21.0	23.5							
4.0	67.2	27.2	19.6	22.1	22.5						
4.5	61.5	25.7	18.4	20.8	20.9	22.5					
5.0	56.5	24.5	17.3	19.7	19.6	21.5					
6.0	48.4	22.3	15.4	17.7	17.3	19.1	18.6				
7.0	40.8	20.5	13.9	16.1	15.5	17.2	18.6	16.2	14.4		
8.0	34.8	19.0	12.7	14.8	14.0	15.7	16.8	16.2	14.4	13.3	
9.0	30.1	17.7	11.6	13.6	12.8	14.3	15.3	16.2	14.4	13.3	12.5
10.0		16.7	10.7	12.6	11.7	13.2	13.9	15.2	14.4	13.3	12.5
12.0		15.1	9.3	11.0	10.0	11.3	11.6	12.9	12.8	13.3	12.5
14.0			8.2	9.8	8.6	9.9	10.0	11.1	10.9	11.9	12.5
16.0			7.3	8.8	7.6	8.8	8.6	9.7	9.4	10.3	11.0
18.0				8.0	6.8	7.8	7.6	8.5	8.2	9.0	9.7
20.0				7.4	6.1	7.1	6.7	7.6	7.2	8.0	8.6
22.0					5.5	6.4	6.0	6.8	6.4	7.1	7.7
24.0					5.1	5.9	5.4	6.1	5.7	6.4	7.0
26.0						5.5	4.9	5.6	5.1	5.8	5.9
28.0						5.1	4.4	5.1	4.6	5.2	5.0
30.0							4.0	4.7	4.1	4.6	4.2
32.0								4.3	3.8	3.9	3.5
34.0								3.9	3.4	3.3	2.9
36.0									3.0	2.8	2.3
38.0									2.6	2.3	1.8
40.0										1.9	1.4
42.0										1.5	1.1
ピン無最大荷重	42.0	31.3	23.4	25.9	22.5	22.5	18.6	16.2	14.4	13.3	12.5
(°)	0~81.5	0~81.5	0~81.5	0~81.5	0~81.5	0~81.5	0~81.5	0~81.5	0~81.5	0~81.5	21~81.5
各ブーム段の伸長状態 (%)											
2段目ブーム	0	0	0	0	0	0	0	0	0	47	93
3段目ブーム	0	0	0	0	0	0	0	47	93	93	93
4段目ブーム	0	0	0	0	0	47	93	93	93	93	93
5段目ブーム	0	0	0	47	93	93	93	93	93	93	93
6段目ブーム	0	47	93	93	93	93	93	93	93	93	93
ワレ掛数	13	4	4	4	4	4	4	4	4	4	4

[ブーム]

C性能

カウンタウエイト 21t
アウトリガ張出幅 6.36m

単位：t

性能番号	12	13	14	15	16	17	18	19	20	21	22	23	24	25	26	27	28
ブーム長さ	19.2m	22.9m	26.7m	30.4m	34.2m	37.9m	41.7m	41.7m	45.4m	52.0m	15.4m	19.2m	22.9m	26.7m	22.9m	26.7m	30.4m
作業半径(m)																	
2.8	32.0	32.0									70.0	64.0	53.3		35.0		
3.0	32.0	32.0									70.0	64.0	53.3		35.0		
3.5	32.0	32.0									70.0	64.0	53.3		35.0	35.0	
4.0	30.5	32.0	32.0								67.5	64.0	53.3	41.5	35.0	35.0	
4.5	29.1	31.7	32.0	29.0							61.8	61.7	52.5	41.5	35.0	35.0	32.1
5.0	27.8	30.4	32.0	29.0							56.9	56.8	49.3	41.5	35.0	35.0	32.1
6.0	25.5	28.1	30.2	29.0	24.9	20.6					48.7	48.6	43.8	38.0	35.0	35.0	32.1
7.0	23.6	26.1	28.2	29.0	24.9	20.6	19.1	16.5			41.2	41.1	39.4	33.9	35.0	35.0	31.6
8.0	21.9	24.4	26.5	28.2	24.9	20.6	19.1	16.5	15.0		35.2	35.0	35.4	30.6	35.0	35.0	28.5
9.0	20.5	22.9	24.9	26.7	24.3	20.6	19.1	16.5	15.0		30.4	30.3	30.7	27.8	32.2	31.9	25.9
10.0	19.3	21.6	23.6	25.3	22.2	20.6	19.1	16.5	15.0	9.7	26.6	26.5	26.8	25.4	28.4	28.0	23.7
12.0	17.3	19.4	21.3	22.8	18.9	17.5	16.6	14.6	15.0	9.7	20.5	20.4	20.7	20.4	22.4	22.0	20.1
14.0	15.9	17.7	18.1	17.7	16.3	15.0	14.2	12.5	13.5	9.7		15.4	15.7	15.4	17.2	16.9	16.4
16.0	14.3	14.6	14.5	14.1	13.6	13.1	12.4	10.9	11.8	9.7		12.0	12.3	11.9	13.7	13.4	12.9
18.0		12.0	11.9	11.5	11.1	11.0	10.8	9.5	10.4	8.9			9.7	9.4	11.1	10.8	10.4
20.0		10.0	9.9	9.5	9.1	9.1	9.2	8.4	9.1	7.9			7.8	7.5	9.2	8.8	8.4
22.0			8.3	8.0	7.5	7.5	7.7	7.5	7.9	7.1				5.8		7.3	6.9
24.0			7.1	6.7	6.3	6.3	6.4	6.7	6.7	6.3				4.5		6.1	5.5
26.0				5.7	5.2	5.1	5.3	6.0	5.6	5.7							4.4
28.0				4.8	4.2	4.2	4.4	5.1	4.7	5.1							3.5
30.0					3.4	3.4	3.5	4.3	3.8	4.3							
32.0						2.7	2.8	3.6	3.1	3.6							
34.0						2.1	2.2	3.0	2.5	3.0							
36.0							1.7	2.4	2.0	2.4							
38.0							1.3	2.0	1.5	1.9							
40.0									1.1	1.5							
42.0										1.1							
ピン無最大荷重	32.0	32.0	32.0	29.0	24.9	20.6	19.1	16.5	15.0	9.7	36.0	34.0	33.0	26.0	33.0	32.0	26.0
(°)	0~81.5	0~81.5	0~81.5	0~81.5	0~81.5	0~81.5	0~81.5	0~81.5	16~81.5	28~81.5	0~81.5	0~81.5	0~81.5	0~81.5	0~81.5	0~81.5	0~81.5
各ブーム段の伸長状態(%)																	
2段目ブーム	0	0	0	47	93	93	93	47	93	100	0	47	47	93	0	47	93
3段目ブーム	0	0	47	47	47	93	93	93	93	100	47	47	93	93	47	47	47
4段目ブーム	0	47	47	47	47	47	93	93	93	100	0	0	0	0	47	47	47
5段目ブーム	47	47	47	47	47	47	47	93	93	100	0	0	0	0	47	47	47
6段目ブーム	47	47	47	47	47	47	47	47	47	100	0	0	0	0	0	0	0
ワイヤ掛数	4	4	4	4	4	4	4	4	4	3	9	8	7	7	5	5	5

[ブーム]

D性能

カウンタウエイト 16 t
アウトリガ張出幅 6.36 m

単位：t

性能番号	1	2	3	4	5	6	7	8	9	10	11
ブーム長さ	11.7m	15.4m	19.2m	22.9m	26.7m	30.4m	34.2m	37.9m	41.7m	45.4m	49.2m
作業半径 (m)											
2.8	84.3	31.3	23.4	25.9							
3.0	80.8	30.5	22.6	25.2							
3.5	73.0	28.8	21.0	23.5							
4.0	66.4	27.2	19.6	22.1	22.5						
4.5	60.7	25.7	18.4	20.8	20.9	22.5					
5.0	55.8	24.5	17.3	19.7	19.6	21.5					
6.0	46.5	22.3	15.4	17.7	17.3	19.1	18.6				
7.0	38.8	20.5	13.9	16.1	15.5	17.2	18.6	16.2	14.4		
8.0	33.1	19.0	12.7	14.8	14.0	15.7	16.8	16.2	14.4	13.3	
9.0	28.5	17.7	11.6	13.6	12.8	14.3	15.3	16.2	14.4	13.3	12.5
10.0		16.7	10.7	12.6	11.7	13.2	13.9	15.2	14.4	13.3	12.5
12.0		15.1	9.3	11.0	10.0	11.3	11.6	12.9	12.8	13.3	12.5
14.0			8.2	9.8	8.6	9.9	10.0	11.1	10.9	11.9	12.5
16.0			7.3	8.8	7.6	8.8	8.6	9.7	9.4	10.3	11.0
18.0				8.0	6.8	7.8	7.6	8.5	8.2	9.0	9.7
20.0				7.4	6.1	7.1	6.7	7.6	7.2	8.0	8.3
22.0					5.5	6.4	6.0	6.8	6.4	7.1	6.9
24.0					5.1	5.9	5.4	6.1	5.7	6.1	5.8
26.0						5.5	4.9	5.6	5.1	5.2	4.8
28.0						5.1	4.4	4.9	4.6	4.4	3.9
30.0							4.0	4.2	3.9	3.6	3.2
32.0								3.6	3.2	3.0	2.5
34.0								3.0	2.7	2.4	2.0
36.0									2.2	1.9	1.5
38.0									1.8	1.5	1.1
40.0										1.2	
ピン無最大荷重	42.0	31.3	23.4	25.9	22.5	22.5	18.6	16.2	14.4	13.3	12.5
(°)	0~81.5	0~81.5	0~81.5	0~81.5	0~81.5	0~81.5	0~81.5	0~81.5	0~81.5	3~81.5	33~81.5
各ブーム段の伸長状態 (%)											
2段目ブーム	0	0	0	0	0	0	0	0	0	47	93
3段目ブーム	0	0	0	0	0	0	0	47	93	93	93
4段目ブーム	0	0	0	0	0	47	93	93	93	93	93
5段目ブーム	0	0	0	47	93	93	93	93	93	93	93
6段目ブーム	0	47	93	93	93	93	93	93	93	93	93
ワイヤ掛数	13	4	4	4	4	4	4	4	4	4	4

[ブーム]

D性能

カウンタウエイト 16 t
アウトリガ張出幅 6.36 m

単位：t

性能番号	12	13	14	15	16	17	18	19	20	21	22	23	24	25	26	27	28
ブーム長さ	19.2m	22.9m	26.7m	30.4m	34.2m	37.9m	41.7m	41.7m	45.4m	52.0m	15.4m	19.2m	22.9m	26.7m	22.9m	26.7m	30.4m
作業半径 (m)																	
2.8	32.0	32.0									70.0	64.0	53.3		35.0		
3.0	32.0	32.0									70.0	64.0	53.3		35.0		
3.5	32.0	32.0									70.0	64.0	53.3		35.0	35.0	
4.0	30.5	32.0	32.0								66.7	64.0	53.3	41.5	35.0	35.0	
4.5	29.1	31.7	32.0	29.0							61.0	60.9	52.5	41.5	35.0	35.0	32.1
5.0	27.8	30.4	32.0	29.0							56.1	56.0	49.3	41.5	35.0	35.0	32.1
6.0	25.5	28.1	30.2	29.0	24.9	20.6					46.9	46.8	43.8	38.0	35.0	35.0	32.1
7.0	23.6	26.1	28.2	29.0	24.9	20.6	19.1	16.5			39.3	39.1	39.4	33.9	35.0	35.0	31.6
8.0	21.9	24.4	26.5	28.2	24.9	20.6	19.1	16.5	15.0		33.5	33.4	33.7	30.6	35.0	34.9	28.5
9.0	20.5	22.9	24.9	26.7	24.3	20.6	19.1	16.5	15.0		28.9	28.8	29.1	27.8	30.7	30.3	25.9
10.0	19.3	21.6	23.6	25.3	22.2	20.6	19.1	16.5	15.0	9.7	25.0	24.8	25.2	24.9	27.0	26.6	23.7
12.0	17.3	19.4	20.6	20.1	18.9	17.5	16.6	14.6	15.0	9.7	17.8	17.7	18.0	17.7	19.7	19.3	18.8
14.0	15.7	16.0	15.8	15.4	15.0	15.0	14.2	12.5	13.5	9.7		13.2	13.5	13.2	15.0	14.7	14.2
16.0	12.4	12.7	12.6	12.2	11.8	11.7	11.9	10.9	11.8	9.7		10.1	10.4	10.1	11.8	11.5	11.0
18.0		10.3	10.2	9.9	9.4	9.4	9.6	9.5	9.8	8.9			8.1	7.8	9.5	9.1	8.7
20.0		8.6	8.4	8.1	7.6	7.6	7.8	8.4	8.0	7.9			6.3	5.9	7.7	7.4	7.0
22.0			7.0	6.6	6.2	6.2	6.4	7.0	6.6	7.0				4.4		6.0	5.5
24.0			5.9	5.5	5.0	5.0	5.2	5.8	5.5	5.9				3.2		4.8	4.2
26.0				4.5	4.0	4.0	4.1	4.9	4.4	4.9							3.2
28.0				3.7	3.1	3.1	3.3	4.0	3.6	4.1							2.4
30.0					2.4	2.3	2.5	3.3	2.8	3.3							
32.0						1.7	1.9	2.6	2.2	2.6							
34.0						1.2	1.3	2.1	1.6	2.1							
36.0							0.9	1.6	1.1	1.6							
38.0								1.2		1.2							
40.0																	
ピン無最大荷重	32.0	32.0	32.0	29.0	24.9	20.6	19.1	16.5	15.0	9.7	36.0	34.0	33.0	26.0	33.0	32.0	26.0
(°)	0~81.5	0~81.5	0~81.5	0~81.5	0~81.5	2~81.5	21~81.5	2~81.5	29~81.5	38~81.5	0~81.5	0~81.5	0~81.5	0~81.5	0~81.5	0~81.5	0~81.5
各ブーム段の伸長状態 (%)																	
2段目ブーム	0	0	0	47	93	93	93	47	93	100	0	47	47	93	0	47	93
3段目ブーム	0	0	47	47	47	93	93	93	93	100	47	47	93	93	47	47	47
4段目ブーム	0	47	47	47	47	47	93	93	93	100	0	0	0	0	47	47	47
5段目ブーム	47	47	47	47	47	47	47	93	93	100	0	0	0	0	47	47	47
6段目ブーム	47	47	47	47	47	47	47	47	47	100	0	0	0	0	0	0	0
ワイヤ掛数	4	4	4	4	4	4	4	4	4	3	9	8	7	7	5	5	5

[ブーム]

E性能

〔カウンタウエイト 9 t〕
〔アウトリガ張出幅 7.2 m〕

〔カウンタウエイト 21 t〕
〔アウトリガ張出幅 4.9 m〕

単位：t

性能番号	1	2	3	4	5	6	7	8	9	10	11
ブーム長さ	11.7m	15.4m	19.2m	22.9m	26.7m	30.4m	34.2m	37.9m	41.7m	45.4m	49.2m
作業半径 (m)											
2.8	79.2	31.3	23.4	25.9							
3.0	75.7	30.5	22.6	25.2							
3.5	67.8	28.8	21.0	23.5							
4.0	61.3	27.2	19.6	22.1	22.5						
4.5	55.7	25.7	18.4	20.8	20.9	22.5					
5.0	50.9	24.5	17.3	19.7	19.6	21.5					
6.0	43.2	22.3	15.4	17.7	17.3	19.1	18.6				
7.0	36.0	20.5	13.9	16.1	15.5	17.2	18.6	16.2	14.4		
8.0	29.8	19.0	12.7	14.8	14.0	15.7	16.8	16.2	14.4	13.3	
9.0	23.8	17.7	11.6	13.6	12.8	14.3	15.3	16.2	14.4	13.3	12.5
10.0		16.7	10.7	12.6	11.7	13.2	13.9	15.2	14.4	13.3	12.5
12.0		15.1	9.3	11.0	10.0	11.3	11.6	12.9	12.8	13.3	12.5
14.0			8.2	9.8	8.6	9.9	10.0	11.1	10.9	11.9	12.5
16.0			7.3	8.8	7.6	8.8	8.6	9.7	9.4	10.1	9.8
18.0				8.0	6.8	7.8	7.6	8.5	8.2	8.1	7.8
20.0				6.9	6.1	7.1	6.7	7.1	6.8	6.6	6.2
22.0					5.5	6.1	5.9	5.9	5.6	5.4	5.0
24.0					4.9	5.1	5.0	4.9	4.7	4.4	4.1
26.0						4.3	4.2	4.1	3.9	3.6	3.3
28.0						3.7	3.5	3.4	3.2	3.0	2.6
30.0							3.0	2.9	2.6	2.4	2.1
32.0								2.4	2.1	1.9	1.6
34.0								2.0	1.7	1.5	1.2
36.0									1.4	1.2	
38.0										1.1	
ピン無最大荷重	42.0	31.3	23.4	25.9	22.5	22.5	18.6	16.2	14.4	13.3	12.5
(°)	0~81.5	0~81.5	0~81.5	0~81.5	0~81.5	0~81.5	0~81.5	0~81.5	3~81.5	26~81.5	40~81.5
各ブーム段の伸長状態 (%)											
2段目ブーム	0	0	0	0	0	0	0	0	0	47	93
3段目ブーム	0	0	0	0	0	0	0	47	93	93	93
4段目ブーム	0	0	0	0	0	47	93	93	93	93	93
5段目ブーム	0	0	0	47	93	93	93	93	93	93	93
6段目ブーム	0	47	93	93	93	93	93	93	93	93	93
ワイヤ掛数	13	4	4	4	4	4	4	4	4	4	4

[ブーム]

E 性能

カウンタウエイト 9 t
アウトリガ張出幅 7.2 m

カウンタウエイト 21 t
アウトリガ張出幅 4.9 m

単位 : t

性能番号	12	13	14	15	16	17	18	19	20	21	22	23	24	25	26	27	28
ブーム長さ	19.2m	22.9m	26.7m	30.4m	34.2m	37.9m	41.7m	41.7m	45.4m	52.0m	15.4m	19.2m	22.9m	26.7m	22.9m	26.7m	30.4m
作業半径 (m)																	
2.8	32.0	32.0									70.0	64.0	53.3		35.0		
3.0	32.0	32.0									70.0	64.0	53.3		35.0		
3.5	32.0	32.0									68.2	64.0	53.3		35.0	35.0	
4.0	30.5	32.0	32.0								61.6	61.5	53.3	41.5	35.0	35.0	
4.5	29.1	31.7	32.0	29.0							56.1	56.0	52.5	41.5	35.0	35.0	32.1
5.0	27.8	30.4	32.0	29.0							51.3	51.2	49.3	41.5	35.0	35.0	32.1
6.0	25.5	28.1	30.2	29.0	24.9	20.6					43.5	43.4	43.7	38.0	35.0	35.0	32.1
7.0	23.6	26.1	28.2	29.0	24.9	20.6	19.1	16.5			36.4	36.3	36.6	33.9	35.0	35.0	31.6
8.0	21.9	24.4	26.5	28.2	24.9	20.6	19.1	16.5	15.0		30.2	30.1	30.5	30.1	32.3	31.9	28.5
9.0	20.5	22.9	24.9	26.7	24.3	20.6	19.1	16.5	15.0		24.3	24.1	24.5	24.2	26.5	26.0	25.5
10.0	19.3	21.6	22.8	22.3	21.7	20.6	19.1	16.5	15.0	9.7	19.7	19.6	20.0	19.6	21.8	21.4	20.9
12.0	16.3	16.6	16.5	16.1	15.6	15.6	15.8	14.6	15.0	9.7	13.8	13.6	14.0	13.7	15.6	15.2	14.8
14.0	12.3	12.7	12.5	12.1	11.7	11.7	11.8	12.5	12.1	9.7		9.9	10.2	9.9	11.7	11.4	10.9
16.0	9.6	9.9	9.8	9.4	9.0	9.0	9.1	9.8	9.4	9.7		7.3	7.6	7.3	9.0	8.7	8.3
18.0		7.9	7.8	7.4	7.0	7.0	7.2	7.8	7.4	7.9			5.7	5.4	7.1	6.7	6.3
20.0		6.4	6.3	5.9	5.5	5.5	5.7	6.3	5.9	6.4			4.3	3.9	5.6	5.3	4.9
22.0			5.1	4.8	4.3	4.3	4.5	5.1	4.7	5.2				2.8		4.1	3.7
24.0			4.2	3.8	3.4	3.4	3.5	4.1	3.8	4.2				2.0		3.2	2.8
26.0				3.0	2.6	2.6	2.7	3.3	3.0	3.4							2.0
28.0				2.4	2.0	1.9	2.1	2.7	2.3	2.7							1.4
30.0					1.4	1.4	1.5	2.1	1.8	2.2							
32.0						0.9	1.1	1.7	1.3	1.7							
34.0								1.2	0.9	1.3							
36.0								0.9		0.9							
38.0																	
ピン無最大荷重	32.0	32.0	32.0	29.0	24.9	20.6	19.1	16.5	15.0	9.7	36.0	34.0	33.0	26.0	33.0	32.0	26.0
(°)	0~81.5	0~81.5	0~81.5	0~81.5	4~81.5	24~81.5	32~81.5	21~81.5	37~81.5	44~81.5	0~81.5	0~81.5	0~81.5	0~81.5	0~81.5	0~81.5	0~81.5
各ブーム段の伸長状態 (%)																	
2段目ブーム	0	0	0	47	93	93	93	47	93	100	0	47	47	93	0	47	93
3段目ブーム	0	0	47	47	47	93	93	93	93	100	47	47	93	93	47	47	47
4段目ブーム	0	47	47	47	47	47	93	93	93	100	0	0	0	0	47	47	47
5段目ブーム	47	47	47	47	47	47	47	93	93	100	0	0	0	0	47	47	47
6段目ブーム	47	47	47	47	47	47	47	47	47	100	0	0	0	0	0	0	0
ワイヤ掛数	4	4	4	4	4	4	4	4	4	3	9	8	7	7	5	5	5

[ブーム]

F性能

カウンタウエイト 9 t	カウンタウエイト 16 t
アウトリガ張出幅 6.36 m	アウトリガ張出幅 4.9 m
カウンタウエイト 21 t	
アウトリガ張出幅 4.0 m	

単位：t

性能番号	1	2	** 3	** 4	** 5	6	7	8	9	10	11
ブーム長さ	11.7m	15.4m	19.2m	22.9m	26.7m	30.4m	34.2m	37.9m	41.7m	45.4m	49.2m
作業半径 (m)											
2.8	74.4	31.3	23.4	25.9							
3.0	70.9	30.5	22.6	25.2							
3.5	63.1	28.8	21.0	23.5							
4.0	56.7	27.2	*19.6	22.1	22.5						
4.5	51.2	25.7	*18.4	20.8	20.9	22.5					
5.0	46.6	24.5	*17.3	*19.7	19.6	21.5					
6.0	38.4	22.3	*15.4	*17.7	*17.3	19.1	18.6				
7.0	29.3	20.5	*13.9	*16.1	*15.5	17.2	18.6	16.2	14.4		
8.0	23.2	19.0	*12.7	*14.8	*14.0	15.7	16.8	16.2	14.4	13.3	
9.0	18.9	17.7	*11.6	*13.6	*12.8	14.3	15.3	16.2	14.4	13.3	12.5
10.0		16.7	*10.7	*12.6	*11.7	13.2	13.9	15.2	14.4	13.3	12.5
12.0		12.8	* 9.3	*11.0	*10.0	11.3	11.6	12.9	12.8	13.3	12.5
14.0			* 8.2	* 9.8	* 8.6	9.9	10.0	11.1	10.9	11.0	10.7
16.0			* 7.3	* 8.8	* 7.6	8.8	8.6	9.2	9.0	8.8	8.4
18.0				* 7.3	* 6.8	7.7	7.6	7.5	7.3	7.1	6.7
20.0				* 6.1	* 6.1	6.4	6.3	6.2	6.0	5.8	5.4
22.0					* 5.1	5.3	5.2	5.2	4.9	4.7	4.3
24.0					* 4.3	4.5	4.4	4.3	4.0	3.8	3.3
26.0						3.7	3.6	3.5	3.2	3.0	2.5
28.0						3.1	2.9	2.8	2.5	2.3	1.9
30.0							2.4	2.3	2.0	1.7	1.3
32.0								1.8	1.5	1.2	
34.0								1.4	1.0		
ピン無最大荷重	42.0	31.3	23.4	25.9	22.5	22.5	18.6	16.2	14.4	13.3	12.5
(°)	0~81.5	0~81.5	0~81.5	0~81.5	0~81.5	0~81.5	0~81.5	0~81.5	25~81.5	40~81.5	50~81.5
**	0~70*	0~75*	0~75*	0~75*	0~75*	0~80*	0~81.5*	0~81.5*	25~81.5*	40~81.5*	50~81.5*
各ブーム段の伸長状態 (%)											
2段目ブーム	0	0	0	0	0	0	0	0	0	47	93
3段目ブーム	0	0	0	0	0	0	0	47	93	93	93
4段目ブーム	0	0	0	0	0	47	93	93	93	93	93
5段目ブーム	0	0	0	47	93	93	93	93	93	93	93
6段目ブーム	0	47	93	93	93	93	93	93	93	93	93
ワイヤ掛数	13	4	4	4	4	4	4	4	4	4	4

注)カウンタウエイト 21 t、アウトリガ張出幅 4.0 mの場合は、**印の箇所が異なり、*印の範囲となります。

[ブーム]

F性能

[カウンタウエイト 9 t] [カウンタウエイト 16 t]
 [アウトリガ張出幅 6.36 m] [アウトリガ張出幅 4.9 m]
 [カウンタウエイト 21 t]
 [アウトリガ張出幅 4.0 m]

単位：t

性能番号	**12	**13	**14	15	16	17	18	19	20	21	22	**23	**24	**25	**26	**27	28
ブーム長さ	19.2m	22.9m	26.7m	30.4m	34.2m	37.9m	41.7m	41.7m	45.4m	52.0m	15.4m	19.2m	22.9m	26.7m	22.9m	26.7m	30.4m
作業半径 (m)																	
2.8	32.0	32.0									70.0	64.0	53.3		35.0		
3.0	32.0	32.0									70.0	64.0	53.3		35.0		
3.5	32.0	32.0									63.4	63.3	53.3		35.0	35.0	
4.0	*30.5	32.0	32.0								57.0	*56.9	53.3	41.5	35.0	35.0	
4.5	*29.1	31.7	32.0	29.0							51.6	*51.5	51.8	41.5	35.0	35.0	32.1
5.0	*27.8	*30.4	32.0	29.0							47.0	*46.8	*47.1	41.5	*35.0	35.0	32.1
6.0	*25.5	*28.1	*30.2	29.0	24.9	20.6					38.9	*38.8	*39.2	*38.0	*35.0	*35.0	32.1
7.0	*23.6	*26.1	*28.2	29.0	24.9	20.6	19.1	16.5			29.8	*29.6	*30.0	*29.7	*31.9	*31.4	30.9
8.0	*21.9	*24.4	*26.5	26.1	24.9	20.6	19.1	16.5	15.0		23.6	*23.5	*23.9	*23.6	*25.6	*25.2	24.7
9.0	*20.5	*22.1	*22.0	21.6	21.1	20.6	19.1	16.5	15.0		19.3	*19.2	*19.5	*19.2	*21.1	*20.8	20.3
10.0	*18.4	*18.7	*18.6	18.2	17.7	17.7	17.9	16.5	15.0	9.7	16.0	*15.9	*16.2	*15.9	*17.8	*17.4	17.0
12.0	*13.7	*14.0	*13.9	13.5	13.0	13.0	13.2	13.9	13.5	9.7	11.4	*11.3	*11.6	*11.3	*13.1	*12.8	12.3
14.0	*10.5	*10.8	*10.7	10.4	9.9	9.9	10.1	10.7	10.3	9.7		* 8.3	* 8.6	* 8.3	*10.0	* 9.6	9.2
16.0	* 8.3	* 8.6	* 8.5	8.1	7.7	7.7	7.8	8.5	8.1	8.5		* 6.0	* 6.3	* 6.0	* 7.7	* 7.4	7.0
18.0		* 6.9	* 6.8	6.4	6.0	6.0	6.2	6.8	6.4	6.8			* 4.5	* 4.2	* 6.1	* 5.8	5.3
20.0		* 5.6	* 5.5	5.1	4.6	4.6	4.8	5.5	5.1	5.5			* 3.1	* 2.7	* 4.7	* 4.3	3.8
22.0			* 4.4	3.9	3.4	3.4	3.6	4.3	3.9	4.4				* 1.6			2.7
24.0			* 3.5	3.0	2.5	2.5	2.7	3.4	3.0	3.5						* 2.3	1.8
26.0				2.2	1.7	1.7	1.9	2.6	2.2	2.7							1.0
28.0				1.6	1.1	1.0	1.2	1.9	1.5	2.0							
30.0								1.4		1.4							
32.0								0.9									
34.0																	
ピン無最大荷重	32.0	32.0	32.0	29.0	24.9	20.6	19.1	16.5	15.0	9.7	36.0	34.0	33.0	26.0	33.0	32.0	26.0
(°)	0~81.5	0~81.5	0~81.5	0~81.5	25~81.5	37~81.5	43~81.5	35~81.5	48~81.5	54~81.5	0~81.5	0~81.5	0~81.5	4~81.5	0~81.5	0~81.5	17~81.5
**	0~75*	0~75*	0~75*	0~80*	25~81.5*	37~81.5*	43~81.5*	35~81.5*	48~81.5*	54~81.5*	0~75*	0~75*	0~75*	4~75*	0~75*	0~75*	17~80*
各ブーム段の伸長状態 (%)																	
2段目ブーム	0	0	0	47	93	93	93	47	93	100	0	47	47	93	0	47	93
3段目ブーム	0	0	47	47	47	93	93	93	93	100	47	47	93	93	47	47	47
4段目ブーム	0	47	47	47	47	47	93	93	93	100	0	0	0	0	47	47	47
5段目ブーム	47	47	47	47	47	47	47	93	93	100	0	0	0	0	47	47	47
6段目ブーム	47	47	47	47	47	47	47	47	47	100	0	0	0	0	0	0	0
ワイヤ掛数	4	4	4	4	4	4	4	4	4	3	9	8	7	7	5	5	5

注)カウンタウエイト21t、アウトリガ張出幅4.0mの場合は、**印の箇所が異なり、*印の範囲となります。

[ブーム]

G性能

〔カウンタウエイト アウトリガ張出幅	16 t	〔カウンタウエイト アウトリガ張出幅	0 t
	4.0 m		7.2 m
〔カウンタウエイト アウトリガ張出幅	9 t	〔カウンタウエイト アウトリガ張出幅	0 t
	4.9 m		6.36 m

単位：t

性能番号	1	2	3	4	5	6	7	8	9	10	11
ブーム長さ	11.7m	15.4m	19.2m	22.9m	26.7m	30.4m	34.2m	37.9m	41.7m	45.4m	49.2m
作業半径 (m)											
2.8	72.8	31.3	23.4	25.9							
3.0	69.3	30.5	22.6	25.2							
3.5	61.6	28.8	21.0	23.5							
4.0	55.2	27.2	19.6	22.1	22.5						
4.5	49.9	25.7	18.4	20.8	20.9	22.5					
5.0	45.3	24.5	17.3	19.7	19.6	21.5					
6.0	33.4	22.3	15.4	17.7	17.3	19.1	18.6				
7.0	25.3	20.5	13.9	16.1	15.5	17.2	18.6	16.2	14.4		
8.0	19.9	19.0	12.7	14.8	14.0	15.7	16.8	16.2	14.4	13.3	
9.0	15.9	17.7	11.6	13.6	12.8	14.3	15.3	16.2	14.4	13.3	12.5
10.0		14.8	10.7	12.6	11.7	13.2	13.9	15.2	14.4	13.3	12.5
12.0		10.2	9.3	11.0	10.0	11.3	11.6	12.4	12.1	11.8	11.4
14.0			8.2	9.0	8.6	9.5	9.4	9.3	9.0	8.8	8.3
16.0			6.1	6.9	7.1	7.3	7.2	7.2	6.9	6.6	6.2
18.0				5.4	5.5	5.8	5.7	5.6	5.3	5.1	4.7
20.0				4.2	4.4	4.6	4.5	4.4	4.1	3.9	3.5
22.0					3.4	3.6	3.5	3.5	3.1	2.9	2.4
24.0					2.6	2.8	2.7	2.6	2.3	2.0	
26.0						2.2	2.0	1.9	1.6		
28.0						1.6	1.4	1.4			
30.0							1.0	0.9			
ピン無最大荷重	42.0	31.3	23.4	25.9	22.5	22.5	18.6	16.2	14.4	13.3	12.5
(°)	0~81.5	0~81.5	0~81.5	0~81.5	0~81.5	0~81.5	12~81.5	32~81.5	46~81.5	54~81.5	62~81.5
**	0~75*	0~80*	0~80*	0~80*	0~81.5*	0~81.5*	12~81.5*	32~81.5*	46~81.5*	54~81.5*	62~81.5*
各ブーム段の伸長状態 (%)											
2段目ブーム	0	0	0	0	0	0	0	0	0	47	93
3段目ブーム	0	0	0	0	0	0	0	47	93	93	93
4段目ブーム	0	0	0	0	0	47	93	93	93	93	93
5段目ブーム	0	0	0	47	93	93	93	93	93	93	93
6段目ブーム	0	47	93	93	93	93	93	93	93	93	93
ワイヤ掛数	13	4	4	4	4	4	4	4	4	4	4

注)カウンタウエイト16t、アウトリガ張出幅4.0mの場合は、**印の箇所が異なり、*印の範囲となります。。

[ブーム]

G性能

カウンタウエイト 16 t	カウンタウエイト 0 t
アウトリガ張出幅 4.0 m	アウトリガ張出幅 7.2 m
カウンタウエイト 9 t	カウンタウエイト 0 t
アウトリガ張出幅 4.9 m	アウトリガ張出幅 6.36 m

単位：t

性能番号	12	13	14	15	16	17	18	19	20	21	22	23	24	25	26	27	28
ブーム長さ	19.2m	22.9m	26.7m	30.4m	34.2m	37.9m	41.7m	41.7m	45.4m	52.0m	15.4m	19.2m	22.9m	26.7m	22.9m	26.7m	30.4m
作業半径 (m)																	
2.8	32.0	32.0									70.0	64.0	53.3		35.0		
3.0	32.0	32.0									69.6	64.0	53.3		35.0		
3.5	32.0	32.0									62.0	61.8	53.3		35.0	35.0	
4.0	30.5	32.0	32.0								55.6	55.5	53.3	41.5	35.0	35.0	
4.5	29.1	31.7	32.0	29.0							50.3	50.1	50.4	41.5	35.0	35.0	32.1
5.0	27.8	30.4	32.0	29.0							45.7	45.6	45.9	41.5	35.0	35.0	32.1
6.0	25.5	28.1	30.2	29.0	24.9	20.6					33.9	33.8	34.2	33.8	35.0	35.0	32.1
7.0	23.6	26.1	28.2	28.4	24.9	20.6	19.1	16.5			25.8	25.6	26.0	25.7	27.9	27.4	26.9
8.0	21.9	23.3	23.2	22.8	22.2	20.6	19.1	16.5	15.0		20.3	20.2	20.5	20.2	22.3	21.9	21.4
9.0	18.9	19.3	19.2	18.7	18.2	18.2	18.4	16.5	15.0		16.3	16.2	16.6	16.2	18.3	17.9	17.4
10.0	15.8	16.1	16.0	15.6	15.1	15.1	15.3	16.0	15.0	9.7	13.2	13.1	13.5	13.1	15.1	14.7	14.3
12.0	11.2	11.6	11.5	11.0	10.5	10.5	10.7	11.5	11.0	9.7	8.7	8.6	8.9	8.6	10.6	10.2	9.7
14.0	8.2	8.5	8.4	8.0	7.5	7.5	7.7	8.4	8.0	8.5	5.7	6.0	5.7	5.7	7.6	7.2	6.8
16.0	6.1	6.4	6.3	5.9	5.5	5.4	5.6	6.3	5.9	6.4	3.5	3.8	3.4	3.4	5.5	5.2	4.7
18.0		4.9	4.8	4.4	3.9	3.8	4.0	4.8	4.4	4.9			2.2	1.8	3.9	3.5	3.0
20.0		3.7	3.6	3.1	2.6	2.5	2.7	3.5	3.1	3.6			1.0		2.7	2.2	1.7
22.0			2.5	2.1	1.5			2.5		2.6							
24.0			1.7	1.3				1.7									
26.0																	
28.0																	
30.0																	
ピン無最大荷重	32.0	32.0	32.0	29.0	24.9	20.6	19.1	16.5	15.0	9.7	36.0	34.0	33.0	26.0	33.0	32.0	26.0
(°)	0~81.5	0~81.5	0~81.5	24~81.5	44~81.5	48~81.5	57~81.5	52~81.5	60~81.5	64~81.5	0~81.5	0~81.5	7~81.5	38~81.5	0~81.5	16~81.5	41~81.5
**	0~80*	0~80*	0~81.5*	24~81.5*	44~81.5*	48~81.5*	57~81.5*	52~81.5*	60~81.5*	64~81.5*	0~80*	0~80*	7~80*	38~81.5*	0~80*	16~81.5*	41~81.5*
各ブーム段の伸長状態 (%)																	
2段目ブーム	0	0	0	47	93	93	93	47	93	100	0	47	47	93	0	47	93
3段目ブーム	0	0	47	47	47	93	93	93	93	100	47	47	93	93	47	47	47
4段目ブーム	0	47	47	47	47	47	93	93	93	100	0	0	0	0	47	47	47
5段目ブーム	47	47	47	47	47	47	47	93	93	100	0	0	0	0	47	47	47
6段目ブーム	47	47	47	47	47	47	47	47	47	100	0	0	0	0	0	0	0
ワイヤ掛数	4	4	4	4	4	4	4	4	4	3	9	8	7	7	5	5	5

注)カウンタウエイト16 t、アウトリガ張出幅4.0 mの場合は、**印の箇所が異なり、*印の範囲となります。。

[ブーム]

H性能	カウンタウエイト 9 t	カウンタウエイト 0 t
	アウトリガ張出幅 4.0 m	アウトリガ張出幅 4.0 m
	カウンタウエイト 0 t	
	アウトリガ張出幅 4.9 m	

I性能	カウンタウエイト 0 t
	アウトリガ張出幅 2.53 m

単位：t

性能番号	1	2	3	12	22	23
ブーム長さ	11.7m	15.4m	19.2m	19.2m	15.4m	19.2m
作業半径 (m)						
2.8	25.0	25.0	23.4	25.0	25.0	25.0
3.0	25.0	25.0	22.6	25.0	25.0	25.0
3.5	25.0	25.0	21.0	25.0	25.0	25.0
4.0	25.0	25.0	19.6	25.0	25.0	25.0
4.5	25.0	25.0	18.4	25.0	25.0	25.0
5.0	25.0	24.5	17.3	25.0	25.0	25.0
6.0	17.0	19.4	15.4	20.7	17.5	17.4
7.0	12.1	14.4	13.9	15.5	12.6	12.5
8.0	8.9	11.0	12.0	12.0	9.4	9.2
9.0	6.6	8.5	9.6	9.5	7.0	6.9
10.0		6.7	7.7	7.7	5.3	5.1
12.0		4.1	5.1	5.1	2.5	2.4
14.0			3.3	3.3		
16.0			1.9	1.9		
(°)	0~81.5	0~81.5	3~81.5	3~81.5	9~81.5	38~81.5
各ブーム段の伸長状態 (%)						
2段目ブーム	0	0	0	0	0	47
3段目ブーム	0	0	0	0	47	47
4段目ブーム	0	0	0	0	0	0
5段目ブーム	0	0	0	47	0	0
6段目ブーム	0	47	93	47	0	0
ワイヤ掛数	13	4	4	4	9	8

単位：t

性能番号	1
ブーム長さ	11.7m
作業半径 (m)	
2.8	8.5
3.0	8.5
3.5	8.5
4.0	8.5
4.5	8.5
5.0	8.5
6.0	8.0
7.0	5.3
8.0	3.2
9.0	1.6
(°)	0~75
各ブーム段の伸長状態 (%)	
2段目ブーム	0
3段目ブーム	0
4段目ブーム	0
5段目ブーム	0
6段目ブーム	0
ワイヤ掛数	13

[ジ ブ]

A性能

カウンタウエイト 21 t
アウトリガ張出幅 7.2 m

49.2 mブーム+フルオートジブ

単位：t

ジブ長さ オフセット	9.0 mジブ				14.0 mジブ				19.0 mジブ															
	5°	25°	45°	60°	5°	25°	45°	60°	5°	25°	45°	60°												
ブーム角度(°)	作業半径 (m)	定格 総荷重	作業半径 (m)	定格 総荷重	作業半径 (m)	定格 総荷重	作業半径 (m)	定格 総荷重	作業半径 (m)	定格 総荷重	作業半径 (m)	定格 総荷重	作業半径 (m)	定格 総荷重										
81.5	8.2	6.10	10.8	5.45	12.6	4.70	13.4	4.50	9.4	3.50	13.7	2.85	16.5	2.10	17.8	1.90	10.9	2.50	16.4	1.25	20.5	0.90	22.4	0.80
80	10.5	6.10	13.0	5.45	14.7	4.70	15.4	4.50	11.9	3.50	16.0	2.85	18.7	2.10	19.8	1.90	13.6	2.50	18.8	1.25	22.7	0.90	24.4	0.80
79	11.7	6.10	14.2	5.45	15.7	4.70	16.4	4.50	13.1	3.50	17.2	2.85	19.7	2.10	20.8	1.90	15.0	2.50	20.0	1.25	23.8	0.90	25.4	0.80
78	12.8	6.10	15.3	5.45	16.8	4.70	17.4	4.50	14.3	3.50	18.3	2.85	20.8	2.10	21.8	1.90	16.3	2.50	21.3	1.25	24.9	0.90	26.4	0.80
75	16.2	6.10	18.4	5.10	19.8	4.55	20.2	4.35	18.0	3.50	21.7	2.75	23.9	2.05	24.7	1.85	20.0	2.25	24.8	1.20	28.1	0.85	29.3	0.75
73	18.5	6.10	20.4	4.90	21.7	4.25	22.0	4.10	20.4	3.50	23.8	2.60	25.9	2.00	26.6	1.85	22.4	2.05	27.1	1.15	30.2	0.85	31.2	0.75
70	21.4	5.20	23.4	4.45	24.4	3.90	24.7	3.80	23.7	3.20	26.9	2.45	28.8	1.95	29.3	1.80	26.0	1.80	30.4	1.05	33.1	0.80	33.9	0.75
68	23.3	4.60	25.2	4.15	26.2	3.70	26.4	3.60	25.9	3.00	29.0	2.35	30.7	1.90	31.0	1.80	28.3	1.70	32.5	1.05	35.1	0.80	35.7	0.75
65	26.1	3.85	27.9	3.65	28.8	3.40	28.9	3.40	29.0	2.70	31.9	2.25	33.4	1.85	33.6	1.80	31.7	1.50	35.6	0.95	37.9	0.80	38.2	0.75
63	27.9	3.45	29.6	3.30	30.4	3.15	30.5	3.15	31.0	2.55	33.9	2.20	35.1	1.85	35.2	1.80	33.8	1.40	37.7	0.95	39.7	0.75	39.8	0.75
60	30.5	2.90	32.0	2.75	32.8	2.70			34.0	2.35	36.6	2.10	37.6	1.80			37.0	1.30	40.5	0.90	42.2	0.75		
58	32.1	2.55	33.7	2.45	34.3	2.40			35.8	2.20	38.4	2.05	39.3	1.80			39.1	1.25	42.4	0.85	43.9	0.75		
55	34.6	1.90	35.9	1.85	36.4	1.80			38.4	1.65	40.7	1.55	41.5	1.50			42.0	1.15	45.1	0.85	46.2	0.75		
53	36.0	1.50	37.3	1.50	37.7	1.45			40.0	1.35	42.1	1.25	42.8	1.20			43.9	1.10	46.7	0.80	47.6	0.75		
50	38.1	1.05	39.3	1.05	39.6	1.00			42.2	0.90	44.2	0.85	44.7	0.85			46.4	0.85	49.1	0.75	49.7	0.70		
48	39.5	0.75	40.6	0.80	40.8	0.75			43.6	0.65	45.5	0.65	45.8	0.60			47.9	0.60						
(°)	47~81.5		47~81.5		47~81.5		62~81.5		47~81.5		47~81.5		47~81.5		62~81.5		47~81.5		49~81.5		49~81.5		62~81.5	

52.0 mブーム+フルオートジブ

単位：t

ジブ長さ オフセット	9.0 mジブ				14.0 mジブ				19.0 mジブ															
	5°	25°	45°	60°	5°	25°	45°	60°	5°	25°	45°	60°												
ブーム角度(°)	作業半径 (m)	定格 総荷重	作業半径 (m)	定格 総荷重	作業半径 (m)	定格 総荷重	作業半径 (m)	定格 総荷重	作業半径 (m)	定格 総荷重	作業半径 (m)	定格 総荷重	作業半径 (m)	定格 総荷重										
81.5	8.7	5.20	11.5	5.20	13.4	4.70	14.1	4.50	10.1	3.50	14.4	2.85	17.2	2.10	18.5	1.90	11.6	2.50	17.1	1.25	21.2	0.90	23.0	0.80
80	11.2	5.20	13.9	5.20	15.6	4.70	16.3	4.50	12.7	3.50	16.9	2.85	19.5	2.10	20.6	1.90	14.4	2.50	19.7	1.25	23.5	0.90	25.2	0.80
79	12.4	5.20	15.1	5.20	16.7	4.70	17.4	4.50	14.1	3.50	18.2	2.85	20.7	2.10	21.7	1.90	15.9	2.50	21.0	1.25	24.7	0.90	26.3	0.80
78	13.7	5.20	16.3	5.20	17.9	4.70	18.4	4.45	15.4	3.50	19.4	2.85	21.8	2.10	22.8	1.90	17.3	2.50	22.3	1.25	25.9	0.90	27.3	0.80
75	17.3	5.20	19.7	5.05	21.0	4.30	21.4	4.10	19.3	3.50	22.9	2.70	25.1	2.05	25.8	1.85	21.3	2.20	26.0	1.20	29.2	0.85	30.4	0.75
73	19.6	5.20	21.8	4.65	22.9	4.00	23.3	3.85	21.8	3.50	25.2	2.55	27.2	2.00	27.8	1.85	23.8	2.00	28.3	1.10	31.4	0.85	32.4	0.75
70	22.8	4.45	24.8	4.15	25.9	3.65	26.1	3.60	25.3	3.15	28.5	2.40	30.2	1.90	30.7	1.80	27.5	1.75	31.8	1.05	34.6	0.80	35.3	0.75
68	24.8	3.95	26.7	3.65	27.8	3.45	27.9	3.40	27.6	2.95	30.6	2.30	32.2	1.90	32.6	1.80	30.0	1.65	34.1	1.00	36.6	0.80	37.2	0.75
65	27.7	3.25	29.5	3.05	30.4	2.95	30.5	2.95	30.9	2.65	33.7	2.20	35.1	1.85	35.3	1.80	33.5	1.50	37.4	0.95	39.5	0.75	39.9	0.75
63	29.5	2.85	31.3	2.75	32.1	2.65	32.1	2.65	33.0	2.45	35.8	2.15	37.0	1.80	37.0	1.80	35.8	1.40	39.5	0.90	41.4	0.75	41.6	0.75
60	32.3	2.40	33.9	2.30	34.5	2.20			35.8	2.00	38.5	1.90	39.6	1.80			39.1	1.30	42.6	0.90	44.1	0.75		
58	34.0	2.00	35.5	1.95	36.1	1.85			37.7	1.75	40.2	1.65	41.2	1.55			41.2	1.20	44.5	0.85	45.9	0.75		
55	36.5	1.40	37.8	1.35	38.3	1.30			40.3	1.20	42.6	1.15	43.4	1.10			44.3	1.15	47.2	0.80	48.3	0.75		
53	38.0	1.05	39.3	1.05	39.7	1.00			41.9	0.90	44.1	0.85	44.8	0.85			46.1	0.85	49.0	0.75	49.8	0.70		
(°)	52~81.5		52~81.5		52~81.5		62~81.5		52~81.5		52~81.5		52~81.5		62~81.5		52~81.5		52~81.5		52~81.5		62~81.5	

[ジブ]

B性能

カウンタウエイト 16 t
アウトリガ張出幅 7.2 m

4.9 mブーム+フルオートジブ

単位：t

ジブ長さ オフセット	9.0 mジブ				14.0 mジブ				19.0 mジブ															
	5°	25°	45°	60°	5°	25°	45°	60°	5°	25°	45°	60°												
ブーム角度(°)	作業半径 (m)	定格 総荷重	作業半径 (m)	定格 総荷重	作業半径 (m)	定格 総荷重	作業半径 (m)	定格 総荷重	作業半径 (m)	定格 総荷重	作業半径 (m)	定格 総荷重	作業半径 (m)	定格 総荷重										
81.5	8.2	6.10	10.8	5.45	12.6	4.70	13.4	4.50	9.4	3.50	13.7	2.85	16.5	2.10	17.8	1.90	10.9	2.50	16.4	1.25	20.5	0.90	22.4	0.80
80	10.5	6.10	13.1	5.45	14.7	4.70	15.4	4.50	11.9	3.50	16.0	2.85	18.7	2.10	19.8	1.90	13.6	2.50	18.8	1.25	22.7	0.90	24.4	0.80
79	11.7	6.10	14.2	5.45	15.7	4.70	16.4	4.50	13.1	3.50	17.2	2.85	19.7	2.10	20.8	1.90	15.0	2.50	20.0	1.25	23.8	0.90	25.4	0.80
78	12.8	6.10	15.3	5.45	16.8	4.70	17.4	4.50	14.3	3.50	18.3	2.85	20.8	2.10	21.8	1.90	16.3	2.50	21.3	1.25	24.9	0.90	26.4	0.80
75	16.2	6.10	18.4	5.10	19.8	4.55	20.2	4.35	18.0	3.50	21.7	2.75	23.9	2.05	24.7	1.85	20.0	2.25	24.8	1.20	28.1	0.85	29.3	0.75
73	18.5	6.10	20.4	4.90	21.7	4.25	22.0	4.10	20.4	3.50	23.8	2.60	25.9	2.00	26.6	1.85	22.4	2.05	27.1	1.15	30.2	0.85	31.2	0.75
70	21.4	5.20	23.4	4.45	24.4	3.90	24.7	3.80	23.7	3.20	26.9	2.45	28.8	1.95	29.3	1.80	26.0	1.80	30.4	1.05	33.1	0.80	33.9	0.75
68	23.3	4.60	25.2	4.15	26.2	3.70	26.4	3.60	25.9	3.00	29.0	2.35	30.7	1.90	31.0	1.80	28.3	1.70	32.5	1.05	35.1	0.80	35.7	0.75
65	26.1	3.65	27.9	3.50	28.8	3.30	28.9	3.25	29.0	2.70	31.9	2.25	33.4	1.85	33.6	1.80	31.7	1.50	35.6	0.95	37.9	0.80	38.2	0.75
63	27.8	2.95	29.6	2.85	30.4	2.70	30.4	2.70	31.0	2.55	33.9	2.20	35.1	1.85	35.2	1.80	33.8	1.40	37.7	0.95	39.7	0.75	39.8	0.75
60	30.3	2.15	31.9	2.10	32.6	2.00			33.9	1.90	36.5	1.75	37.6	1.65			37.0	1.30	40.5	0.90	42.2	0.75		
58	31.8	1.65	33.4	1.65	34.0	1.55			35.5	1.50	38.1	1.35	39.1	1.30			39.1	1.25	42.4	0.85	43.9	0.75		
55	34.2	1.10	35.6	1.10	36.1	1.05			37.9	0.95	40.3	0.90	41.2	0.85			41.9	0.90	45.1	0.75	46.2	0.70		
53	35.6	0.75	37.0	0.75	37.4	0.75																		
(°)	52~81.5		52~81.5		52~81.5		62~81.5		54~81.5		54~81.5		54~81.5		62~81.5		54~81.5		54~81.5		54~81.5		62~81.5	

5.2 mブーム+フルオートジブ

単位：t

ジブ長さ オフセット	9.0 mジブ				14.0 mジブ				19.0 mジブ															
	5°	25°	45°	60°	5°	25°	45°	60°	5°	25°	45°	60°												
ブーム角度(°)	作業半径 (m)	定格 総荷重	作業半径 (m)	定格 総荷重	作業半径 (m)	定格 総荷重	作業半径 (m)	定格 総荷重	作業半径 (m)	定格 総荷重	作業半径 (m)	定格 総荷重	作業半径 (m)	定格 総荷重										
81.5	8.7	5.20	11.5	5.20	13.4	4.70	14.1	4.50	10.1	3.50	14.4	2.85	17.2	2.10	18.5	1.90	11.6	2.50	17.1	1.25	21.2	0.90	23.0	0.80
80	11.2	5.20	13.9	5.20	15.6	4.70	16.3	4.50	12.7	3.50	16.9	2.85	19.5	2.10	20.6	1.90	14.4	2.50	19.7	1.25	23.5	0.90	25.2	0.80
79	12.4	5.20	15.1	5.20	16.7	4.70	17.4	4.50	14.1	3.50	18.2	2.85	20.7	2.10	21.7	1.90	15.9	2.50	21.0	1.25	24.7	0.90	26.3	0.80
78	13.7	5.20	16.3	5.20	17.9	4.70	18.4	4.45	15.4	3.50	19.4	2.85	21.8	2.10	22.8	1.90	17.3	2.50	22.3	1.25	25.9	0.90	27.3	0.80
75	17.3	5.20	19.7	5.05	21.0	4.30	21.4	4.10	19.3	3.50	22.9	2.70	25.1	2.05	25.8	1.85	21.3	2.20	26.0	1.20	29.2	0.85	30.4	0.75
73	19.6	5.20	21.8	4.65	22.9	4.00	23.3	3.85	21.8	3.50	25.2	2.55	27.2	2.00	27.8	1.85	23.8	2.00	28.3	1.10	31.4	0.85	32.4	0.75
70	22.8	4.45	24.8	4.15	25.9	3.65	26.1	3.60	25.3	3.15	28.5	2.40	30.2	1.90	30.7	1.80	27.5	1.75	31.8	1.05	34.6	0.80	35.3	0.75
68	24.8	3.95	26.7	3.65	27.8	3.45	27.9	3.40	27.6	2.95	30.6	2.30	32.2	1.90	32.6	1.80	30.0	1.65	34.1	1.00	36.6	0.80	37.2	0.75
65	27.7	3.05	29.5	2.90	30.4	2.70	30.5	2.65	30.9	2.65	33.7	2.20	35.1	1.85	35.3	1.80	33.5	1.50	37.4	0.95	39.5	0.75	39.9	0.75
63	29.5	2.40	31.2	2.30	32.0	2.15	32.0	2.15	32.9	2.10	35.8	1.90	37.0	1.80	37.0	1.80	35.8	1.40	39.5	0.90	41.4	0.75	41.6	0.75
60	32.0	1.60	33.6	1.55	34.3	1.50			35.6	1.40	38.3	1.30	39.4	1.25			39.1	1.30	42.6	0.90	44.1	0.75		
58	33.7	1.20	35.2	1.15	35.8	1.10			37.3	1.00	39.8	0.95	40.9	0.90			41.2	1.00	44.5	0.80	45.9	0.75		
(°)	57~81.5		57~81.5		57~81.5		62~81.5		57~81.5		57~81.5		57~81.5		62~81.5		57~81.5		57~81.5		57~81.5		62~81.5	

[ジ ブ]

C性能

カウンタウエイト 21t
アウトリガ張出幅 6.36m

49.2mブーム+フルオートジブ

単位：t

ジブ長さ オフセット	9.0 mジブ				14.0 mジブ				19.0 mジブ															
	5°	25°	45°	60°	5°	25°	45°	60°	5°	25°	45°	60°												
ブーム角度(°)	作業半径 (m)	定格 総荷重	作業半径 (m)	定格 総荷重	作業半径 (m)	定格 総荷重	作業半径 (m)	定格 総荷重	作業半径 (m)	定格 総荷重	作業半径 (m)	定格 総荷重												
81.5	8.2	6.10	10.8	5.45	12.6	4.70	13.4	4.50	9.4	3.50	13.7	2.85	16.5	2.10	17.8	1.90	10.9	2.50	16.4	1.25	20.5	0.90	22.4	0.80
80	10.5	6.10	13.1	5.45	14.7	4.70	15.4	4.50	11.9	3.50	16.0	2.85	18.7	2.10	19.8	1.90	13.6	2.50	18.8	1.25	22.7	0.90	24.4	0.80
79	11.7	6.10	14.2	5.45	15.7	4.70	16.4	4.50	13.1	3.50	17.2	2.85	19.7	2.10	20.8	1.90	15.0	2.50	20.0	1.25	23.8	0.90	25.4	0.80
78	12.8	6.10	15.3	5.45	16.8	4.70	17.4	4.50	14.3	3.50	18.3	2.85	20.8	2.10	21.8	1.90	16.3	2.50	21.3	1.25	24.9	0.90	26.4	0.80
75	16.2	6.10	18.4	5.10	19.8	4.55	20.2	4.35	18.0	3.50	21.7	2.75	23.9	2.05	24.7	1.85	20.0	2.25	24.8	1.20	28.1	0.85	29.3	0.75
73	18.5	6.10	20.4	4.90	21.7	4.25	22.0	4.10	20.4	3.50	23.8	2.60	25.9	2.00	26.6	1.85	22.4	2.05	27.1	1.15	30.2	0.85	31.2	0.75
70	21.4	5.20	23.4	4.45	24.4	3.90	24.7	3.80	23.7	3.20	26.9	2.45	28.8	1.95	29.3	1.80	26.0	1.80	30.4	1.05	33.1	0.80	33.9	0.75
68	23.3	4.60	25.2	4.15	26.2	3.70	26.4	3.60	25.9	3.00	29.0	2.35	30.7	1.90	31.0	1.80	28.3	1.70	32.5	1.05	35.1	0.80	35.7	0.75
65	26.1	3.85	27.9	3.65	28.8	3.40	28.9	3.40	29.0	2.70	31.9	2.25	33.4	1.85	33.6	1.80	31.7	1.50	35.6	0.95	37.9	0.80	38.2	0.75
63	27.9	3.45	29.6	3.30	30.4	3.15	30.5	3.15	31.0	2.55	33.9	2.20	35.1	1.85	35.2	1.80	33.8	1.40	37.7	0.95	39.7	0.75	39.8	0.75
60	30.5	2.90	32.0	2.75	32.8	2.70			34.0	2.35	36.6	2.10	37.6	1.80			37.0	1.30	40.5	0.90	42.2	0.75		
58	32.0	2.35	33.6	2.30	34.2	2.20			35.8	2.10	38.3	1.95	39.3	1.80			39.1	1.25	42.4	0.85	43.9	0.75		
55	34.3	1.60	35.7	1.60	36.2	1.55			38.1	1.40	40.4	1.30	41.3	1.25			42.0	1.15	45.1	0.85	46.2	0.75		
53	35.8	1.15	37.1	1.20	37.5	1.15			39.6	1.00	41.9	0.95	42.6	0.90			43.7	0.95	46.7	0.80	47.6	0.75		
(°)	52~81.5		52~81.5		52~81.5		62~81.5		52~81.5		52~81.5		52~81.5		62~81.5		52~81.5		52~81.5		52~81.5		62~81.5	

52.0mブーム+フルオートジブ

単位：t

ジブ長さ オフセット	9.0 mジブ				14.0 mジブ				19.0 mジブ															
	5°	25°	45°	60°	5°	25°	45°	60°	5°	25°	45°	60°												
ブーム角度(°)	作業半径 (m)	定格 総荷重	作業半径 (m)	定格 総荷重	作業半径 (m)	定格 総荷重	作業半径 (m)	定格 総荷重	作業半径 (m)	定格 総荷重	作業半径 (m)	定格 総荷重												
81.5	8.7	5.20	11.5	5.20	13.4	4.70	14.1	4.50	10.1	3.50	14.4	2.85	17.2	2.10	18.5	1.90	11.6	2.50	17.1	1.25	21.2	0.90	23.0	0.80
80	11.2	5.20	13.9	5.20	15.6	4.70	16.3	4.50	12.7	3.50	16.9	2.85	19.5	2.10	20.6	1.90	14.4	2.50	19.7	1.25	23.5	0.90	25.2	0.80
79	12.4	5.20	15.1	5.20	16.7	4.70	17.4	4.50	14.1	3.50	18.2	2.85	20.7	2.10	21.7	1.90	15.9	2.50	21.0	1.25	24.7	0.90	26.3	0.80
78	13.7	5.20	16.3	5.20	17.9	4.70	18.4	4.45	15.4	3.50	19.4	2.85	21.8	2.10	22.8	1.90	17.3	2.50	22.3	1.25	25.9	0.90	27.3	0.80
75	17.3	5.20	19.7	5.05	21.0	4.30	21.4	4.10	19.3	3.50	22.9	2.70	25.1	2.05	25.8	1.85	21.3	2.20	26.0	1.20	29.2	0.85	30.4	0.75
73	19.6	5.20	21.8	4.65	22.9	4.00	23.3	3.85	21.8	3.50	25.2	2.55	27.2	2.00	27.8	1.85	23.8	2.00	28.3	1.10	31.4	0.85	32.4	0.75
70	22.8	4.45	24.8	4.15	25.9	3.65	26.1	3.60	25.3	3.15	28.5	2.40	30.2	1.90	30.7	1.80	27.5	1.75	31.8	1.05	34.6	0.80	35.3	0.75
68	24.8	3.95	26.7	3.65	27.8	3.45	27.9	3.40	27.6	2.95	30.6	2.30	32.2	1.90	32.6	1.80	30.0	1.65	34.1	1.00	36.6	0.80	37.2	0.75
65	27.7	3.25	29.5	3.05	30.4	2.95	30.5	2.95	30.9	2.65	33.7	2.20	35.1	1.85	35.3	1.80	33.5	1.50	37.4	0.95	39.5	0.75	39.9	0.75
63	29.5	2.85	31.3	2.75	32.1	2.65	32.1	2.65	33.0	2.45	35.8	2.15	37.0	1.80	37.0	1.80	35.8	1.40	39.5	0.90	41.4	0.75	41.6	0.75
60	32.2	2.30	33.8	2.20	34.5	2.10			35.8	1.95	38.5	1.85	39.6	1.75			39.1	1.30	42.6	0.90	44.1	0.75		
58	33.8	1.75	35.4	1.70	35.9	1.60			37.5	1.50	40.0	1.40	41.1	1.35			41.2	1.20	44.5	0.85	45.9	0.75		
55	36.2	1.05	37.6	1.05	38.1	0.95																		
(°)	54~81.5		54~81.5		54~81.5		62~81.5		57~81.5		57~81.5		57~81.5		62~81.5		57~81.5		57~81.5		57~81.5		62~81.5	

[ジ ブ]

D性能

カウンタウエイト 16 t
アウトリガ張出幅 6.36 m

49.2mブーム+フルオートジブ

単位：t

ジブ長さ オフセット	9.0 mジブ				14.0 mジブ				19.0 mジブ															
	5°	25°	45°	60°	5°	25°	45°	60°	5°	25°	45°	60°												
ブーム角度(°)	作業半径 (m)	定格 総荷重	作業半径 (m)	定格 総荷重	作業半径 (m)	定格 総荷重	作業半径 (m)	定格 総荷重	作業半径 (m)	定格 総荷重	作業半径 (m)	定格 総荷重	作業半径 (m)	定格 総荷重										
81.5	8.2	6.10	10.8	5.45	12.6	4.70	13.4	4.50	9.4	3.50	13.7	2.85	16.5	2.10	17.8	1.90	10.9	2.50	16.4	1.25	20.5	0.90	22.4	0.80
80	10.5	6.10	13.1	5.45	14.7	4.70	15.4	4.50	11.9	3.50	16.0	2.85	18.7	2.10	19.8	1.90	13.6	2.50	18.8	1.25	22.7	0.90	24.4	0.80
79	11.7	6.10	14.2	5.45	15.7	4.70	16.4	4.50	13.1	3.50	17.2	2.85	19.7	2.10	20.8	1.90	15.0	2.50	20.0	1.25	23.8	0.90	25.4	0.80
78	12.8	6.10	15.3	5.45	16.8	4.70	17.4	4.50	14.3	3.50	18.3	2.85	20.8	2.10	21.8	1.90	16.3	2.50	21.3	1.25	24.9	0.90	26.4	0.80
75	16.2	6.10	18.4	5.10	19.8	4.55	20.2	4.35	18.0	3.50	21.7	2.75	23.9	2.05	24.7	1.85	20.0	2.25	24.8	1.20	28.1	0.85	29.3	0.75
73	18.5	6.10	20.4	4.90	21.7	4.25	22.0	4.10	20.4	3.50	23.8	2.60	25.9	2.00	26.6	1.85	22.4	2.05	27.1	1.15	30.2	0.85	31.2	0.75
70	21.4	5.20	23.4	4.45	24.4	3.90	24.7	3.80	23.7	3.20	26.9	2.45	28.8	1.95	29.3	1.80	26.0	1.80	30.4	1.05	33.1	0.80	33.9	0.75
68	23.3	4.60	25.2	4.15	26.2	3.70	26.4	3.60	25.9	3.00	29.0	2.35	30.7	1.90	31.0	1.80	28.3	1.70	32.5	1.05	35.1	0.80	35.7	0.75
65	26.0	3.70	27.9	3.60	28.8	3.35	28.9	3.35	29.0	2.70	31.9	2.25	33.4	1.85	33.6	1.80	31.7	1.50	35.6	0.95	37.9	0.80	38.2	0.75
63	27.6	2.90	29.4	2.85	30.3	2.70	30.3	2.65	31.0	2.55	33.9	2.20	35.1	1.85	35.2	1.80	33.8	1.40	37.7	0.95	39.7	0.75	39.8	0.75
60	30.0	1.95	31.7	1.90	32.4	1.80			33.5	1.70	36.3	1.60	37.5	1.50			37.0	1.30	40.5	0.90	42.2	0.75		
58	31.6	1.40	33.2	1.40	33.8	1.35			35.2	1.25	37.8	1.15	38.9	1.10			39.0	1.15						
(°)	57~81.5		57~81.5		57~81.5		62~81.5		57~81.5		57~81.5		57~81.5		62~81.5		57~81.5		59~81.5		59~81.5		62~81.5	

52.0mブーム+フルオートジブ

単位：t

ジブ長さ オフセット	9.0 mジブ				14.0 mジブ				19.0 mジブ															
	5°	25°	45°	60°	5°	25°	45°	60°	5°	25°	45°	60°												
ブーム角度(°)	作業半径 (m)	定格 総荷重	作業半径 (m)	定格 総荷重	作業半径 (m)	定格 総荷重	作業半径 (m)	定格 総荷重	作業半径 (m)	定格 総荷重	作業半径 (m)	定格 総荷重	作業半径 (m)	定格 総荷重										
81.5	8.7	5.20	11.5	5.20	13.4	4.70	14.1	4.50	10.1	3.50	14.4	2.85	17.2	2.10	18.5	1.90	11.6	2.50	17.1	1.25	21.2	0.90	23.0	0.80
80	11.2	5.20	13.9	5.20	15.6	4.70	16.3	4.50	12.7	3.50	16.9	2.85	19.5	2.10	20.6	1.90	14.4	2.50	19.7	1.25	23.5	0.90	25.2	0.80
79	12.4	5.20	15.1	5.20	16.7	4.70	17.4	4.50	14.1	3.50	18.2	2.85	20.7	2.10	21.7	1.90	15.9	2.50	21.0	1.25	24.7	0.90	26.3	0.80
78	13.7	5.20	16.3	5.20	17.9	4.70	18.4	4.45	15.4	3.50	19.4	2.85	21.8	2.10	22.8	1.90	17.3	2.50	22.3	1.25	25.9	0.90	27.3	0.80
75	17.3	5.20	19.7	5.05	21.0	4.30	21.4	4.10	19.3	3.50	22.9	2.70	25.1	2.05	25.8	1.85	21.3	2.20	26.0	1.20	29.2	0.85	30.4	0.75
73	19.6	5.20	21.8	4.65	22.9	4.00	23.3	3.85	21.8	3.50	25.2	2.55	27.2	2.00	27.8	1.85	23.8	2.00	28.3	1.10	31.4	0.85	32.4	0.75
70	22.8	4.45	24.8	4.15	25.9	3.65	26.1	3.60	25.3	3.15	28.5	2.40	30.2	1.90	30.7	1.80	27.5	1.75	31.8	1.05	34.6	0.80	35.3	0.75
68	24.8	3.95	26.7	3.65	27.8	3.45	27.9	3.40	27.6	2.95	30.6	2.30	32.2	1.90	32.6	1.80	30.0	1.65	34.1	1.00	36.6	0.80	37.2	0.75
65	27.5	3.00	29.4	2.85	30.3	2.65	30.4	2.65	30.8	2.55	33.7	2.20	35.1	1.85	35.3	1.80	33.5	1.50	37.4	0.95	39.5	0.75	39.9	0.75
63	29.2	2.25	31.0	2.15	31.8	2.00	31.8	2.00	32.5	1.90	35.5	1.80	36.9	1.70	36.9	1.65	35.8	1.40	39.5	0.90	41.4	0.75	41.6	0.75
(°)	62~81.5		62~81.5		62~81.5		62~81.5		62~81.5		62~81.5		62~81.5		62~81.5		62~81.5		62~81.5		62~81.5		62~81.5	

[ジ ブ]

E性能 [カウンタウエイト 9 t] [カウンタウエイト 21 t]
 [アウトリガ張出幅 7.2 m] [アウトリガ張出幅 4.9 m]

49.2 mブーム+フルオートジブ

単位: t

ジブ長さ オフセット	9.0 mジブ				14.0 mジブ				19.0 mジブ			
	5°	25°	45°	60°	5°	25°	45°	60°	5°	25°	45°	60°
ブーム角度(°)	作業半径 定格 (m) 総荷重	作業半径 定格 (m) 総荷重	作業半径 定格 (m) 総荷重	作業半径 定格 (m) 総荷重	作業半径 定格 (m) 総荷重	作業半径 定格 (m) 総荷重	作業半径 定格 (m) 総荷重	作業半径 定格 (m) 総荷重	作業半径 定格 (m) 総荷重	作業半径 定格 (m) 総荷重	作業半径 定格 (m) 総荷重	作業半径 定格 (m) 総荷重
81.5	8.2 6.10	10.8 5.45	12.6 4.70	13.4 4.50	9.4 3.50	13.7 2.85	16.5 2.10	17.8 1.90	10.9 2.50	16.4 1.25	20.5 0.90	22.4 0.80
80	10.5 6.10	13.1 5.45	14.7 4.70	15.4 4.50	11.9 3.50	16.0 2.85	18.7 2.10	19.8 1.90	13.6 2.50	18.8 1.25	22.7 0.90	24.4 0.80
79	11.7 6.10	14.2 5.45	15.7 4.70	16.4 4.50	13.1 3.50	17.2 2.85	19.7 2.10	20.8 1.90	15.0 2.50	20.0 1.25	23.8 0.90	25.4 0.80
78	12.8 6.10	15.3 5.45	16.8 4.70	17.4 4.50	14.3 3.50	18.3 2.85	20.8 2.10	21.8 1.90	16.3 2.50	21.3 1.25	24.9 0.90	26.4 0.80
75	16.2 6.10	18.4 5.10	19.8 4.55	20.2 4.35	18.0 3.50	21.7 2.75	23.9 2.05	24.7 1.85	20.0 2.25	24.8 1.20	28.1 0.85	29.3 0.75
73	18.5 6.10	20.4 4.90	21.7 4.25	22.0 4.10	20.4 3.50	23.8 2.60	25.9 2.00	26.6 1.85	22.4 2.05	27.1 1.15	30.2 0.85	31.2 0.75
70	21.2 4.25	23.3 3.95	24.4 3.65	24.7 3.60	23.7 3.20	26.9 2.45	28.8 1.95	29.3 1.80	26.0 1.80	30.4 1.05	33.1 0.80	33.9 0.75
68	22.9 3.30	24.9 3.15	26.0 2.90	26.2 2.85	25.9 2.95	29.0 2.35	30.7 1.90	31.0 1.80	28.3 1.70	32.5 1.05	35.1 0.80	35.7 0.75
65	25.5 2.20	27.4 2.15	28.3 2.00	28.5 1.95	28.7 1.95	31.7 1.75	33.3 1.60	33.5 1.60	31.7 1.50	35.6 0.95	37.9 0.80	38.2 0.75
63	27.2 1.60	29.0 1.60	29.9 1.50	29.9 1.50	30.4 1.45	33.4 1.30	34.9 1.20	35.0 1.20	33.8 1.35	37.7 0.95	39.7 0.75	39.8 0.75
(°)	62~81.5	62~81.5	62~81.5	62~81.5	62~81.5	62~81.5	62~81.5	62~81.5	62~81.5	62~81.5	62~81.5	62~81.5

52.0 mブーム+フルオートジブ

単位: t

ジブ長さ オフセット	9.0 mジブ				14.0 mジブ				19.0 mジブ			
	5°	25°	45°	60°	5°	25°	45°	60°	5°	25°	45°	60°
ブーム角度(°)	作業半径 定格 (m) 総荷重	作業半径 定格 (m) 総荷重	作業半径 定格 (m) 総荷重	作業半径 定格 (m) 総荷重	作業半径 定格 (m) 総荷重	作業半径 定格 (m) 総荷重	作業半径 定格 (m) 総荷重	作業半径 定格 (m) 総荷重	作業半径 定格 (m) 総荷重	作業半径 定格 (m) 総荷重	作業半径 定格 (m) 総荷重	作業半径 定格 (m) 総荷重
81.5	8.7 5.20	11.5 5.20	13.4 4.70	14.1 4.50	10.1 3.50	14.4 2.85	17.2 2.10	18.5 1.90	11.6 2.50	17.1 1.25	21.2 0.90	23.0 0.80
80	11.2 5.20	13.9 5.20	15.6 4.70	16.3 4.50	12.7 3.50	16.9 2.85	19.5 2.10	20.6 1.90	14.4 2.50	19.7 1.25	23.5 0.90	25.2 0.80
79	12.4 5.20	15.1 5.20	16.7 4.70	17.4 4.50	14.1 3.50	18.2 2.85	20.7 2.10	21.7 1.90	15.9 2.50	21.0 1.25	24.7 0.90	26.3 0.80
78	13.7 5.20	16.3 5.20	17.9 4.70	18.4 4.45	15.4 3.50	19.4 2.85	21.8 2.10	22.8 1.90	17.3 2.50	22.3 1.25	25.9 0.90	27.3 0.80
75	17.3 5.20	19.7 5.05	21.0 4.30	21.4 4.10	19.3 3.50	22.9 2.70	25.1 2.05	25.8 1.85	21.3 2.20	26.0 1.20	29.2 0.85	30.4 0.75
73	19.6 5.20	21.8 4.65	22.9 4.00	23.3 3.85	21.8 3.50	25.2 2.55	27.2 2.00	27.8 1.85	23.8 2.00	28.3 1.10	31.4 0.85	32.4 0.75
70	22.5 3.50	24.6 3.30	25.7 3.00	26.0 2.95	25.3 3.05	28.5 2.40	30.2 1.90	30.7 1.80	27.5 1.75	31.8 1.05	34.6 0.80	35.3 0.75
68	24.3 2.65	26.3 2.50	27.3 2.30	27.6 2.25	27.3 2.30	30.6 2.05	32.2 1.90	32.6 1.80	30.0 1.65	34.1 1.00	36.6 0.80	37.2 0.75
65	27.0 1.65	28.8 1.60	29.8 1.45	29.9 1.45	30.1 1.40	33.2 1.30	34.8 1.20	35.0 1.20	33.5 1.40	37.4 0.95		
(°)	64~81.5	64~81.5	64~81.5	64~81.5	64~81.5	64~81.5	64~81.5	64~81.5	64~81.5	64~81.5	67~81.5	67~81.5

[ジ ブ]

F性能 [カウンタウエイト 9 t] [カウンタウエイト 16 t]
 [アウトリガ張出幅 6.36 m] [アウトリガ張出幅 4.9 m]

49.2 mブーム+フルオートジブ

単位：t

ジブ長さ オフセット	9.0 mジブ				14.0 mジブ				19.0 mジブ															
	5°	25°	45°	60°	5°	25°	45°	60°	5°	25°	45°	60°												
ブーム角度(°)	作業半径 (m)	定格 総荷重	作業半径 (m)	定格 総荷重	作業半径 (m)	定格 総荷重	作業半径 (m)	定格 総荷重	作業半径 (m)	定格 総荷重	作業半径 (m)	定格 総荷重	作業半径 (m)	定格 総荷重										
81.5	8.2	6.10	10.8	5.45	12.6	4.70	13.4	4.50	9.4	3.50	13.7	2.85	16.5	2.10	17.8	1.90	10.9	2.50	16.4	1.25	20.5	0.90	22.4	0.80
80	10.5	6.10	13.1	5.45	14.7	4.70	15.4	4.50	11.9	3.50	16.0	2.85	18.7	2.10	19.8	1.90	13.6	2.50	18.8	1.25	22.7	0.90	24.4	0.80
79	11.7	6.10	14.2	5.45	15.7	4.70	16.4	4.50	13.1	3.50	17.2	2.85	19.7	2.10	20.8	1.90	15.0	2.50	20.0	1.25	23.8	0.90	25.4	0.80
78	12.8	6.10	15.3	5.45	16.8	4.70	17.4	4.50	14.3	3.50	18.3	2.85	20.8	2.10	21.8	1.90	16.3	2.50	21.3	1.25	24.9	0.90	26.4	0.80
75	16.2	6.10	18.4	5.10	19.8	4.55	20.2	4.35	18.0	3.50	21.7	2.75	23.9	2.05	24.7	1.85	20.0	2.25	24.8	1.20	28.1	0.85	29.3	0.75
73	18.4	5.85	20.4	4.90	21.7	4.25	22.0	4.10	20.4	3.50	23.8	2.60	25.9	2.00	26.6	1.85	22.4	2.05	27.1	1.15	30.2	0.85	31.2	0.75
70	21.0	3.90	23.1	3.70	24.2	3.40	24.5	3.35	23.7	3.20	26.9	2.45	28.8	1.95	29.3	1.80	26.0	1.80	30.4	1.05	33.1	0.80	33.9	0.75
68	22.7	2.90	24.7	2.75	25.8	2.55	26.0	2.55	25.6	2.55	28.9	2.25	30.7	1.90	31.0	1.80	28.3	1.70	32.5	1.05	35.1	0.80	35.7	0.75
(°)	67~81.5		67~81.5		67~81.5		67~81.5		67~81.5		67~81.5		67~81.5		67~81.5		67~81.5		67~81.5		67~81.5		67~81.5	

52.0 mブーム+フルオートジブ

単位：t

ジブ長さ オフセット	9.0 mジブ				14.0 mジブ				19.0 mジブ															
	5°	25°	45°	60°	5°	25°	45°	60°	5°	25°	45°	60°												
ブーム角度(°)	作業半径 (m)	定格 総荷重	作業半径 (m)	定格 総荷重	作業半径 (m)	定格 総荷重	作業半径 (m)	定格 総荷重	作業半径 (m)	定格 総荷重	作業半径 (m)	定格 総荷重	作業半径 (m)	定格 総荷重										
81.5	8.7	5.20	11.5	5.20	13.4	4.70	14.1	4.50	10.1	3.50	14.4	2.85	17.2	2.10	18.5	1.90	11.6	2.50	17.1	1.25	21.2	0.90	23.0	0.80
80	11.2	5.20	13.9	5.20	15.6	4.70	16.3	4.50	12.7	3.50	16.9	2.85	19.5	2.10	20.6	1.90	14.4	2.50	19.7	1.25	23.5	0.90	25.2	0.80
79	12.4	5.20	15.1	5.20	16.7	4.70	17.4	4.50	14.1	3.50	18.2	2.85	20.7	2.10	21.7	1.90	15.9	2.50	21.0	1.25	24.7	0.90	26.3	0.80
78	13.7	5.20	16.3	5.20	17.9	4.70	18.4	4.45	15.4	3.50	19.4	2.85	21.8	2.10	22.8	1.90	17.3	2.50	22.3	1.25	25.9	0.90	27.3	0.80
75	17.3	5.20	19.7	5.05	21.0	4.30	21.4	4.10	19.3	3.50	22.9	2.70	25.1	2.05	25.8	1.85	21.3	2.20	26.0	1.20	29.2	0.85	30.4	0.75
73	19.5	4.90	21.7	4.55	22.9	4.00	23.3	3.85	21.8	3.50	25.2	2.55	27.2	2.00	27.8	1.85	23.8	2.00	28.3	1.10	31.4	0.85	32.4	0.75
70	22.2	3.10	24.3	2.95	25.4	2.65	25.7	2.60	25.0	2.65	28.5	2.40	30.2	1.90	30.7	1.80	27.5	1.75	31.8	1.05	34.6	0.80	35.3	0.75
(°)	69~81.5		69~81.5		69~81.5		69~81.5		69~81.5		69~81.5		69~81.5		69~81.5		69~81.5		69~81.5		69~81.5		69~81.5	

[ジ ブ]

G性能 [カウンタウエイト 9 t
アウトリガ張出幅 4.9 m]

4.9. 2mブーム+フルオートジブ

単位：t

ジブ長さ オフセット	9.0 mジブ				14.0 mジブ				19.0 mジブ															
	5°	25°	45°	60°	5°	25°	45°	60°	5°	25°	45°	60°												
ブーム角度(°)	作業半径 (m)	定格 総荷重	作業半径 (m)	定格 総荷重	作業半径 (m)	定格 総荷重	作業半径 (m)	定格 総荷重	作業半径 (m)	定格 総荷重	作業半径 (m)	定格 総荷重												
81.5	8.2	6.10	10.8	5.45	12.6	4.70	13.4	4.50	9.4	3.50	13.7	2.85	16.5	2.10	17.8	1.90	10.9	2.50	16.4	1.25	20.5	0.90	22.4	0.80
80	10.5	6.10	13.1	5.45	14.7	4.70	15.4	4.50	11.9	3.50	16.0	2.85	18.7	2.10	19.8	1.90	13.6	2.50	18.8	1.25	22.7	0.90	24.4	0.80
79	11.7	6.10	14.2	5.45	15.7	4.70	16.4	4.50	13.1	3.50	17.2	2.85	19.7	2.10	20.8	1.90	15.0	2.50	20.0	1.25	23.8	0.90	25.4	0.80
78	12.8	6.10	15.3	5.45	16.8	4.70	17.4	4.50	14.3	3.50	18.3	2.85	20.8	2.10	21.8	1.90	16.3	2.50	21.3	1.25	24.9	0.90	26.4	0.80
75	16.0	5.10	18.3	4.70	19.7	4.20	20.1	4.05	18.0	3.50	21.7	2.75	23.9	2.05	24.7	1.85	20.0	2.25	24.8	1.20	28.1	0.85	29.3	0.75
73	17.7	3.65	19.9	3.40	21.2	3.10	21.7	3.00	20.3	3.25	23.8	2.60	25.9	2.00	26.6	1.85	22.4	2.05	27.1	1.15				
(°)	72~81.5		72~81.5		72~81.5		72~81.5		72~81.5		72~81.5		72~81.5		72~81.5		72~81.5		72~81.5		74~81.5		74~81.5	

5.2. 0mブーム+フルオートジブ

単位：t

ジブ長さ オフセット	9.0 mジブ				14.0 mジブ				19.0 mジブ															
	5°	25°	45°	60°	5°	25°	45°	60°	5°	25°	45°	60°												
ブーム角度(°)	作業半径 (m)	定格 総荷重	作業半径 (m)	定格 総荷重	作業半径 (m)	定格 総荷重	作業半径 (m)	定格 総荷重	作業半径 (m)	定格 総荷重	作業半径 (m)	定格 総荷重												
81.5	8.7	5.20	11.5	5.20	13.4	4.70	14.1	4.50	10.1	3.50	14.4	2.85	17.2	2.10	18.5	1.90	11.6	2.50	17.1	1.25	21.2	0.90	23.0	0.80
80	11.2	5.20	13.9	5.20	15.6	4.70	16.3	4.50	12.7	3.50	16.9	2.85	19.5	2.10	20.6	1.90	14.4	2.50	19.7	1.25	23.5	0.90	25.2	0.80
79	12.4	5.20	15.1	5.20	16.7	4.70	17.4	4.50	14.1	3.50	18.2	2.85	20.7	2.10	21.7	1.90	15.9	2.50	21.0	1.25	24.7	0.90	26.3	0.80
78	13.7	5.20	16.3	5.20	17.9	4.70	18.4	4.45	15.4	3.50	19.4	2.85	21.8	2.10	22.8	1.90	17.3	2.50	22.3	1.25	25.9	0.90	27.3	0.80
75	16.9	4.20	19.2	3.85	20.6	3.40	21.1	3.30	19.3	3.50	22.9	2.70	25.1	2.05	25.8	1.85	21.3	2.20	26.0	1.20				
(°)	74~81.5		74~81.5		74~81.5		74~81.5		74~81.5		74~81.5		74~81.5		74~81.5		74~81.5		74~81.5		77~81.5		77~81.5	

- (注) 1. 定格総荷重は、アウトリガを水平堅土上に設置したときの値で、太線より上側はクレーンの強度に基づき、下側は、クレーンの安定に基づいています。
2. 定格総荷重は、つり具質量とフック質量(100トンフック：820kg, 50トンフック：700kg, 8トンフック：250kg)を含んだ値を示します。
3. 定格総荷重は、ブームのたわみを含んだ実際の作業半径に基づいています。
4. 定格総荷重表の性能区分A～Iは、下表のとおりです。

アウトリガ張出幅 \ かつたて	21 t	16 t	9t	5t または0t
7.2 m	A	B	E	G *
6.36m	C	D	F	G *
4.9 m	E	F	G	H *
4.0 m	F *	G *	H *	H *
2.53m				I *

- ・ 同じ性能区分・ブーム長さでも、各ブーム段の伸長状態によって定格総荷重が異なります。
 - ・ * 印は、ブームの性能のみです。
 - ・ H性能は、11.7m、15.4mおよび19.2mブームのみです。
 - ・ I性能は、11.7mブームのみです。
5. 各ブーム長さにおけるフックのワイヤロープ標準巻掛本数は、ブームの各定格総荷重表の最下段に記載しています。
ただし、この掛数以外で使用する場合は、ロープ1本当り主巻・補巻ともに8.0t以下としてください。
・ シングルトップまたはジブ使用時の巻掛本数は1(8tフック使用)です。
6. シングルトップの定格総荷重は、ブームの定格総荷重よりブームに取り付けられているフックの重量を差し引いた値とし、かつ限度は8.0tです。
7. ジブの定格総荷重は、ブーム長さ49.2m以下を選択した場合と52.0mブームを選択した場合で異なります。
8. ジブ作業はブーム角度基準で行ってください。
なお、ジブの作業半径は49.2m、および52.0mブームにジブを装着した場合の参考値を示します。
9. 定格総荷重表中の は、無負荷時のブーム起伏角度範囲です。
10. 瞬間最大風速が10m/s以上の風速では、クレーン作業を中止してください。

3. 作業半径 - 揚程図

A性能(1)

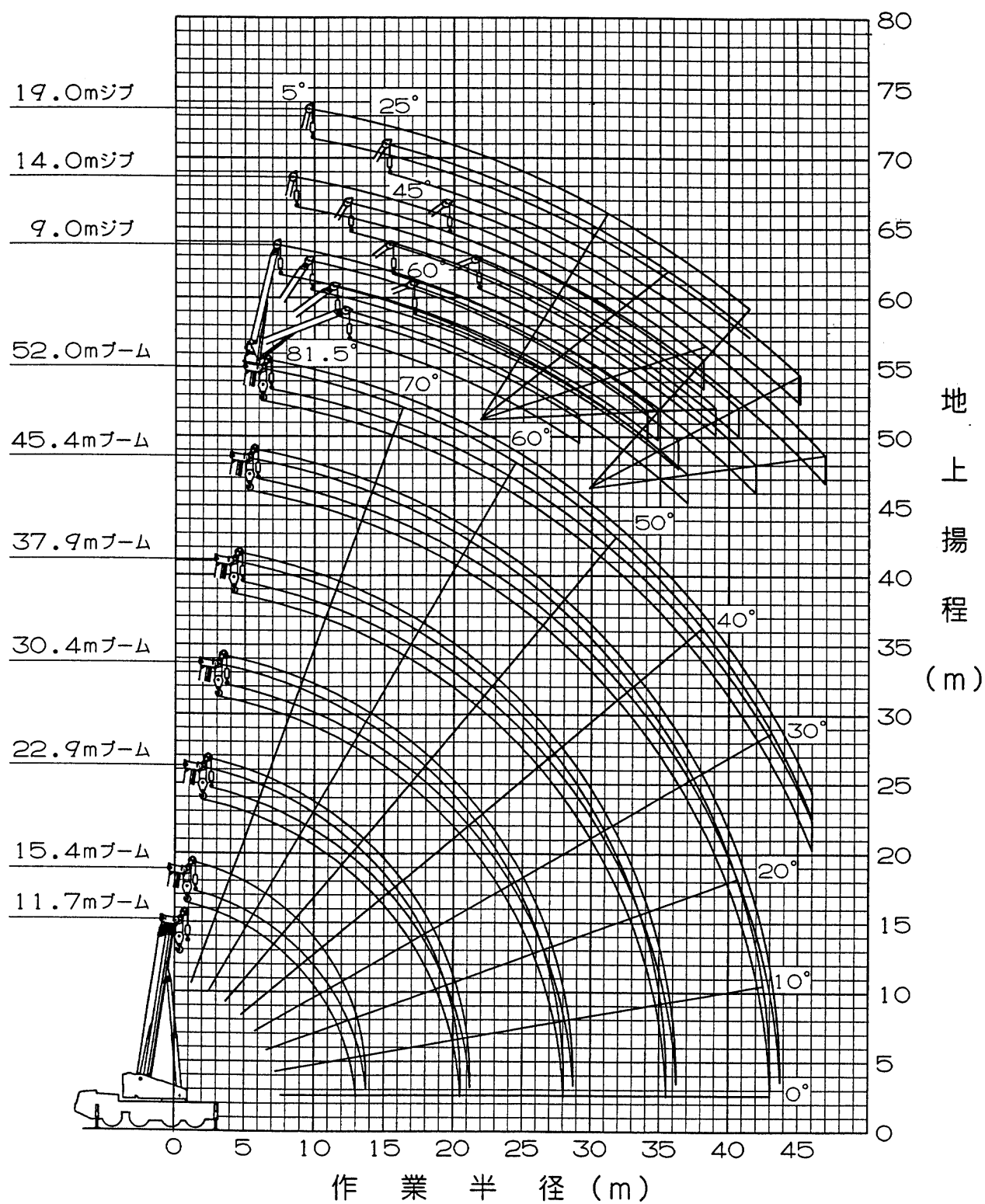

(注) 上図はボーム及びジブのたわみを含んでいません。

A性能(2)

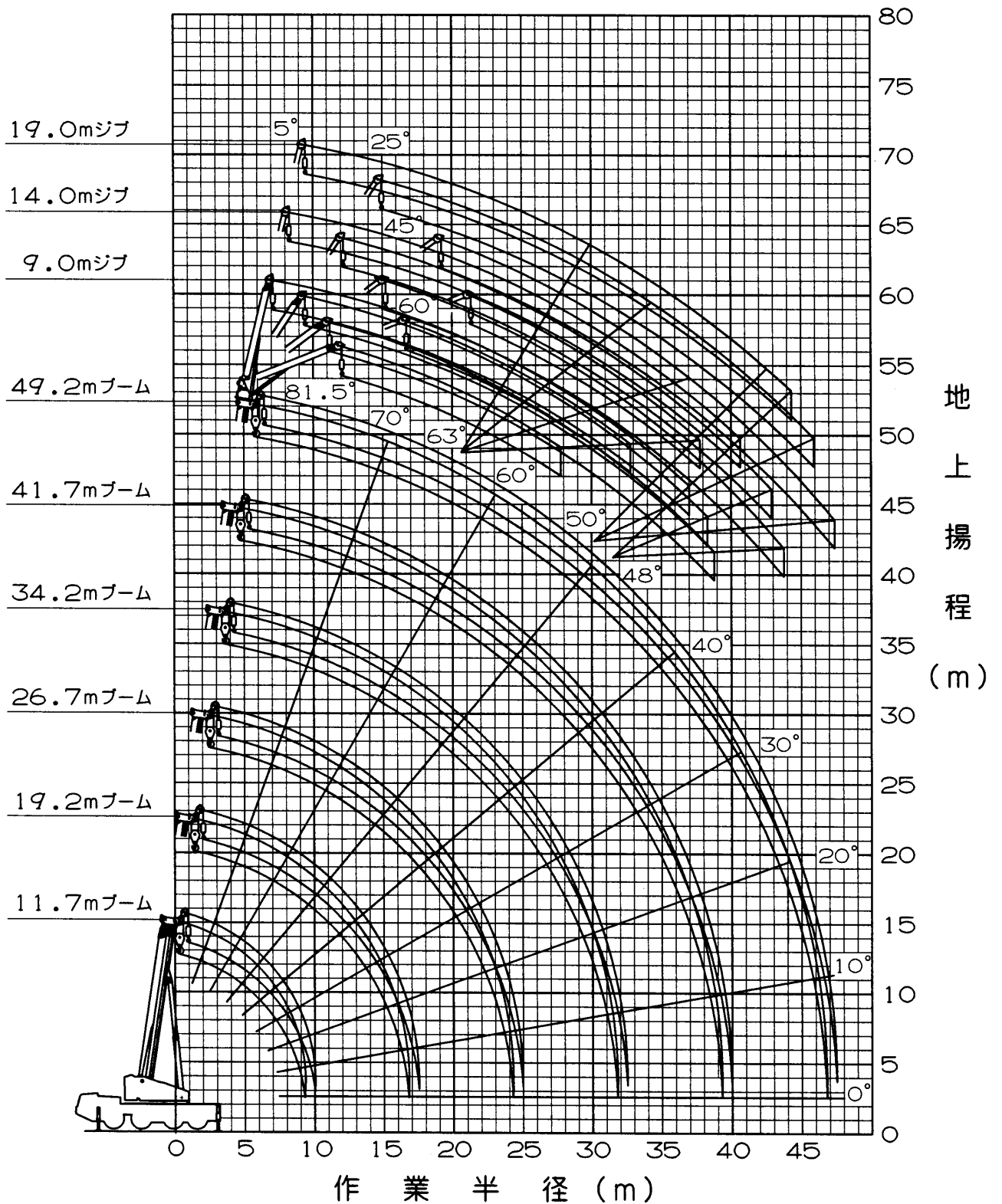

(注) 上図はブーム及びジブのたわみを含んでいません。

4. 外觀圖 [公道走行状態]

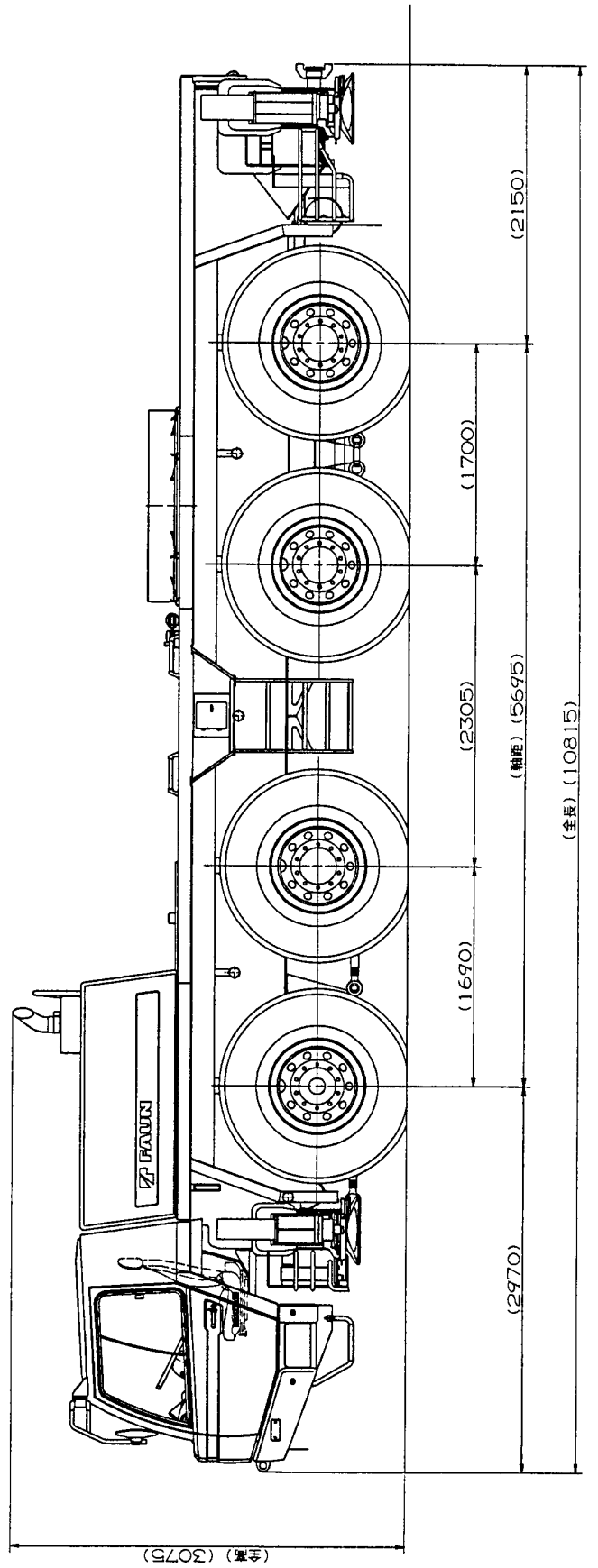
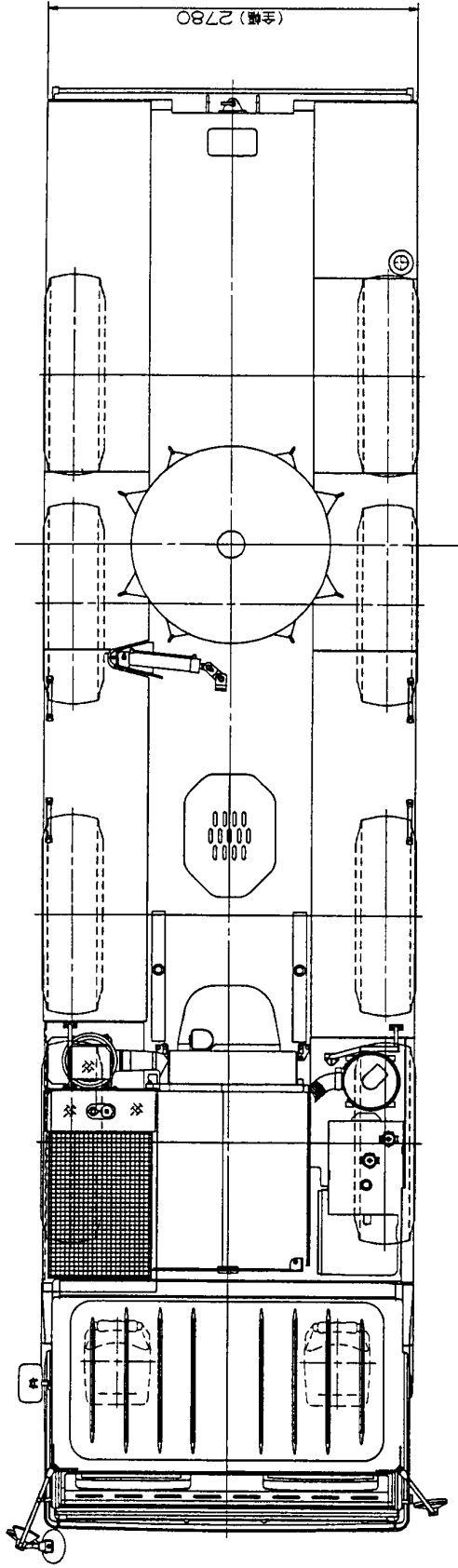

[構内走行状態図]

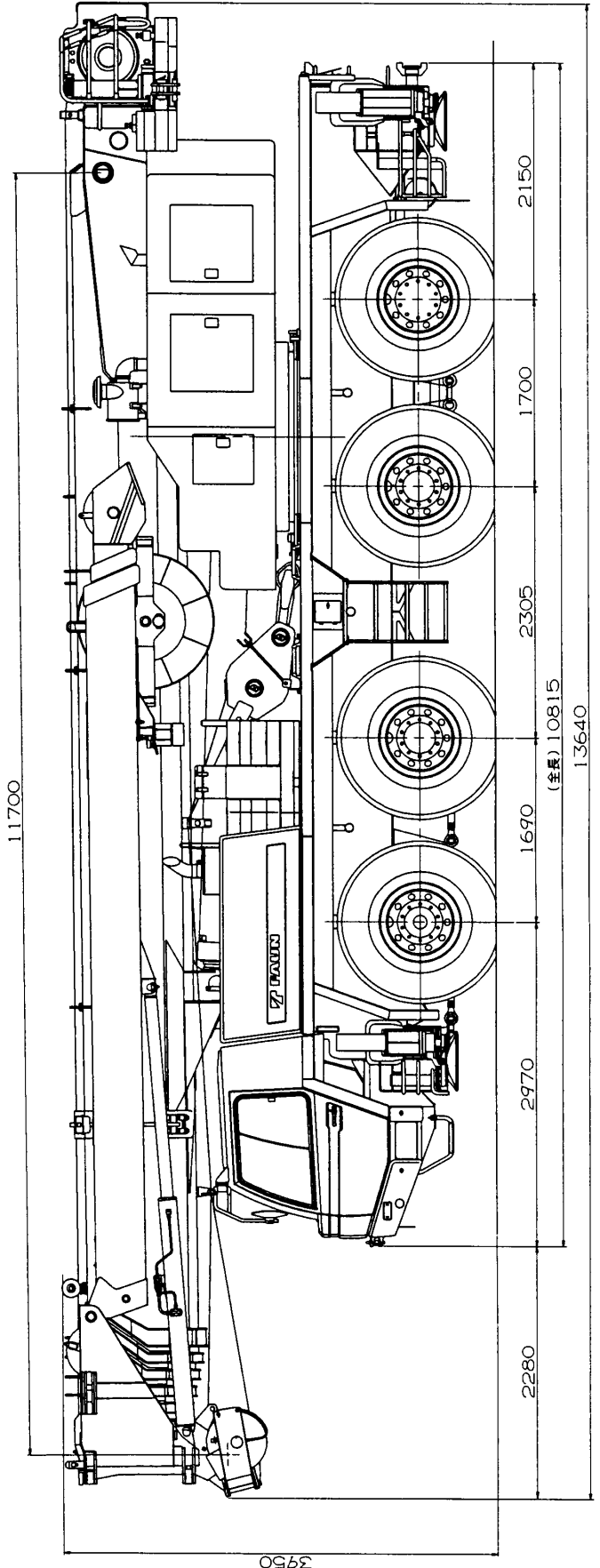
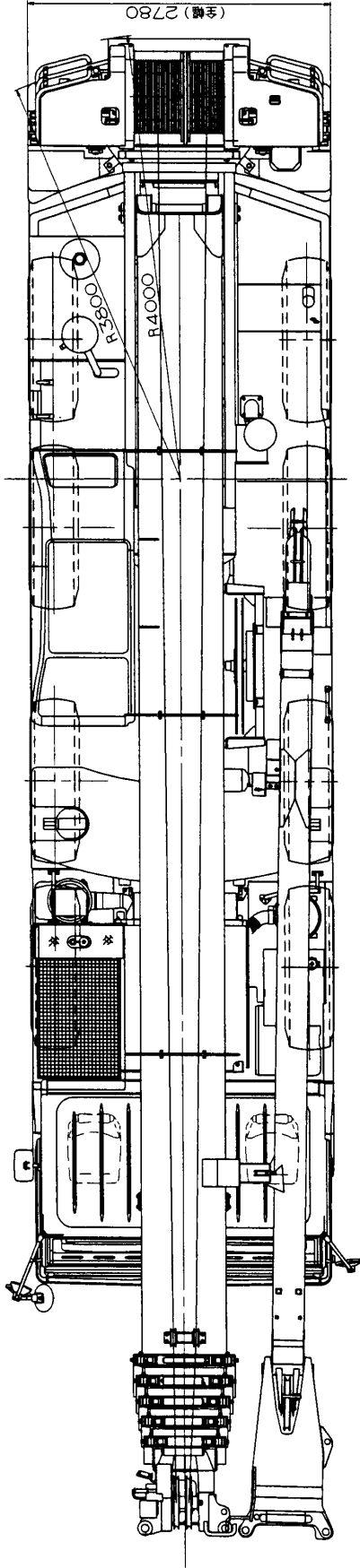

寸法・重量関係

■ 構内走行状態

単位(mm)

縮尺1/100

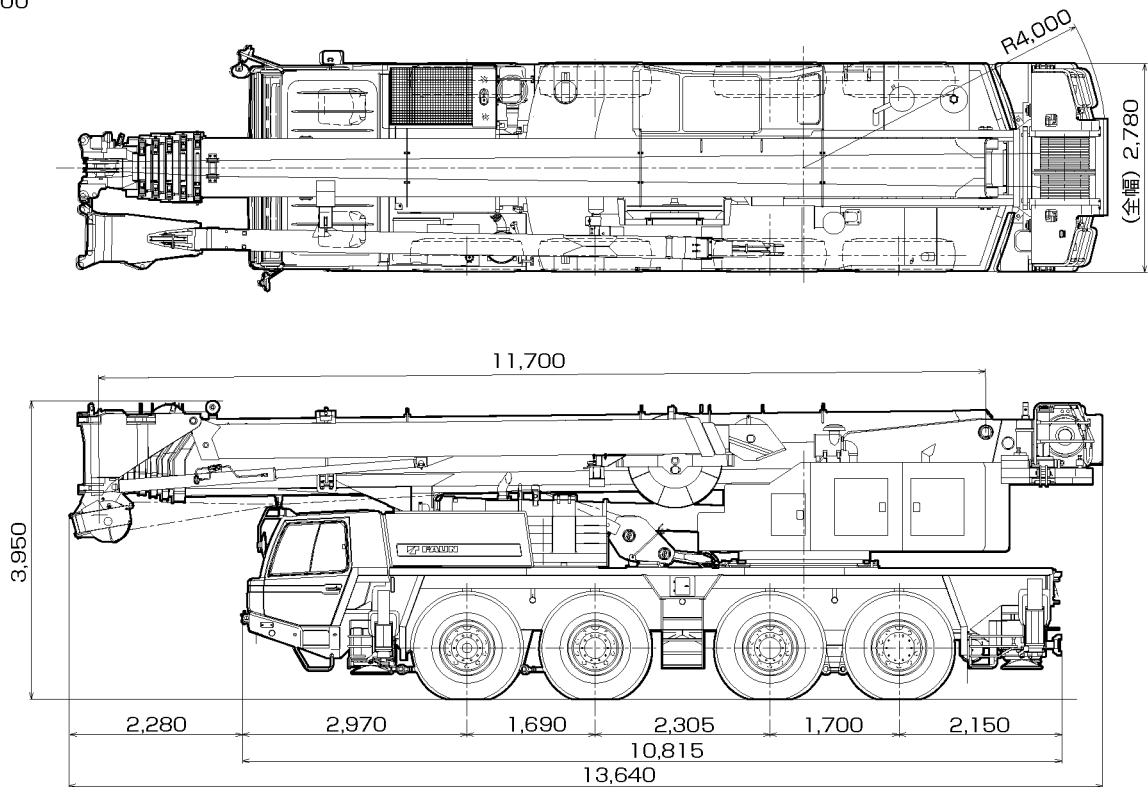

■ 公道走行状態

単位(mm)

縮尺1/100

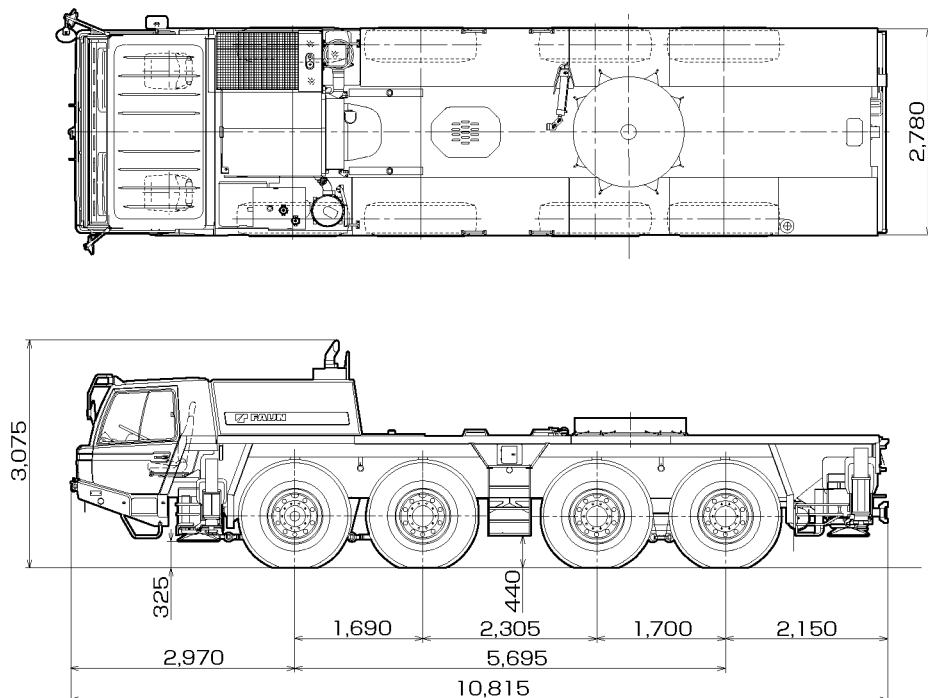

(注意) 1.本機は、公道を走行する場合には、旋回体及びブームを別送し、台車のみで走行しなければなりません。
2.道路法による基本通行条件のA条件適合車です。

寸法・重量関係

■ 主要寸法

単位(mm)

縮尺1/100

3段フルオートジブ

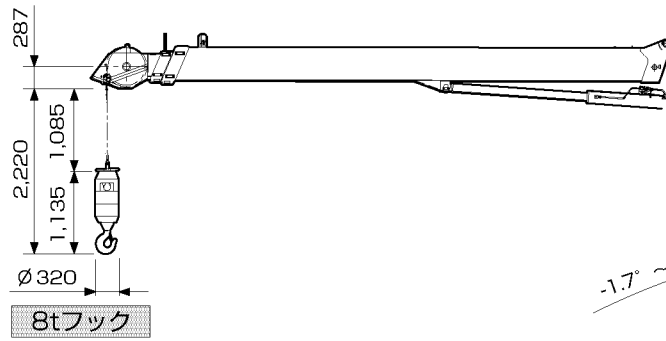

ブーム

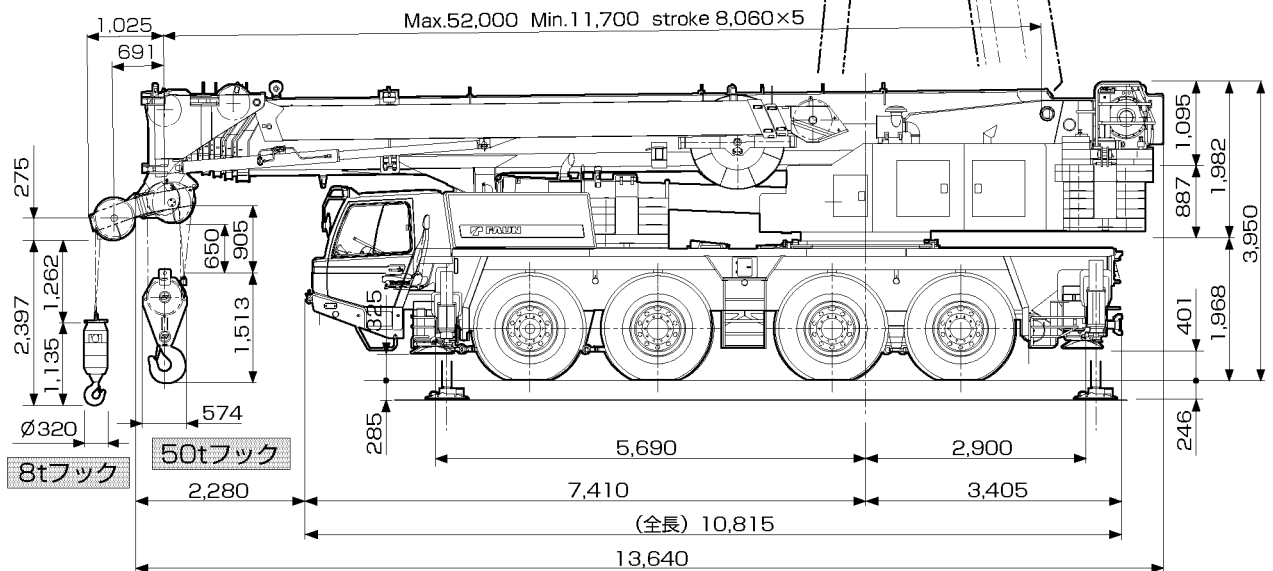
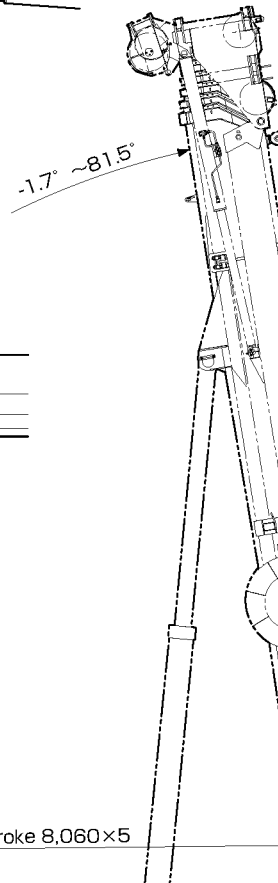
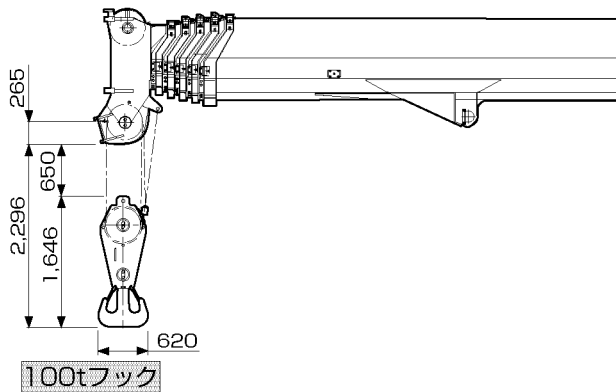

寸法・重量関係

単位(mm)

縮尺1/100

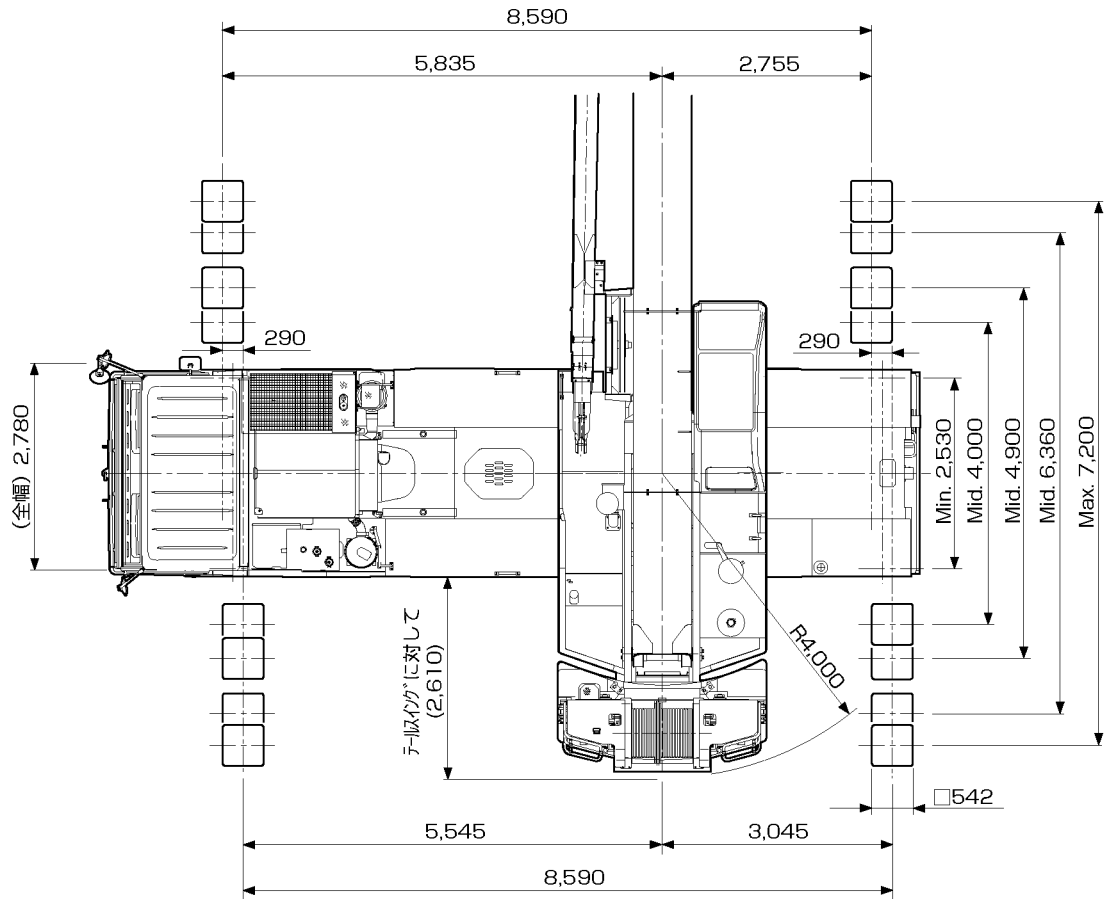

■ 最小直角通路幅

単位(mm)

ノーマルステアリング (前4輪)

クランプステアリング (8輪)

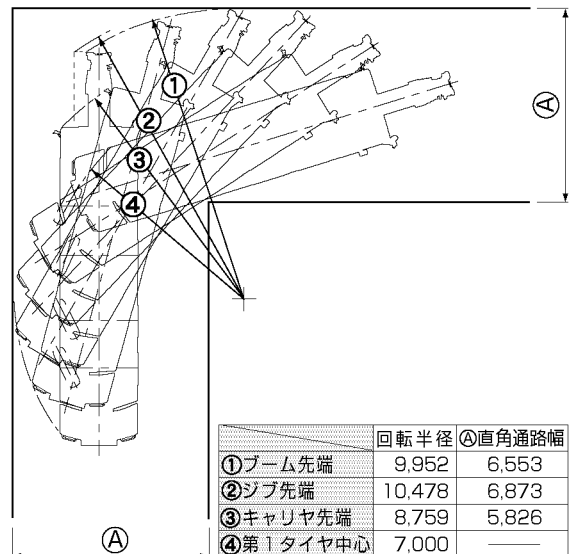
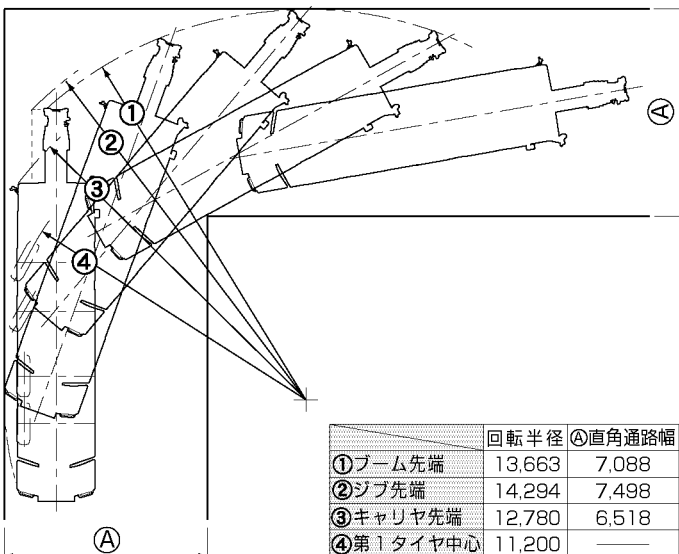

寸法・重量関係

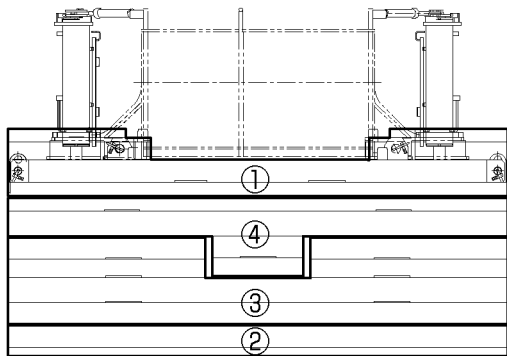

■カウンタウエイト質量表

ウエイト	質量
①	5t
②	4t
③	7t
④	5t

■カウンタウエイト組合せ表

ウエイト呼び	組合せ
21t	①+②+③+④
16t	①+②+③
9t	①+②
5t	①

■カウンタウエイト寸法図

単位(mm)

① 固定ウエイト 5t

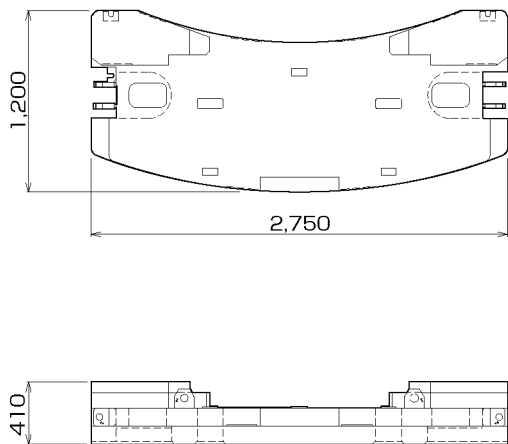

② STDウエイト 4t

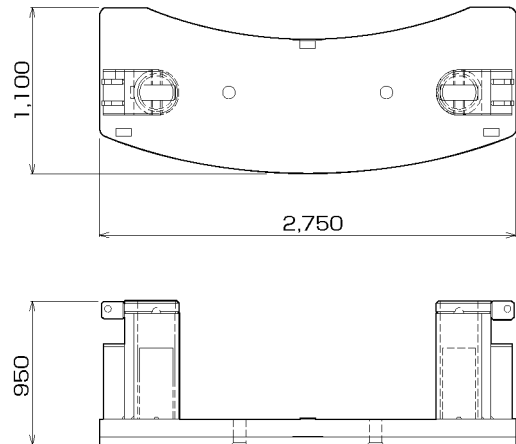

③ STDウエイト 7t

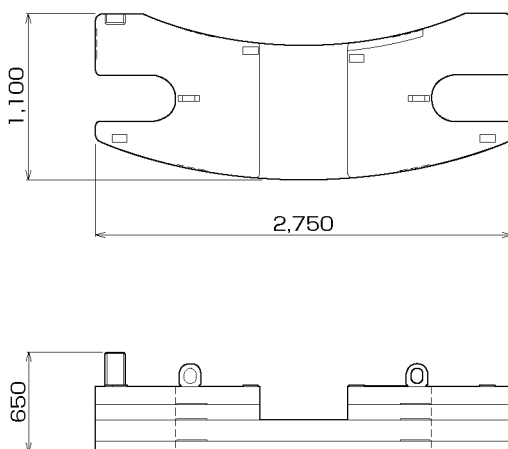

④ EXTウエイト 5t

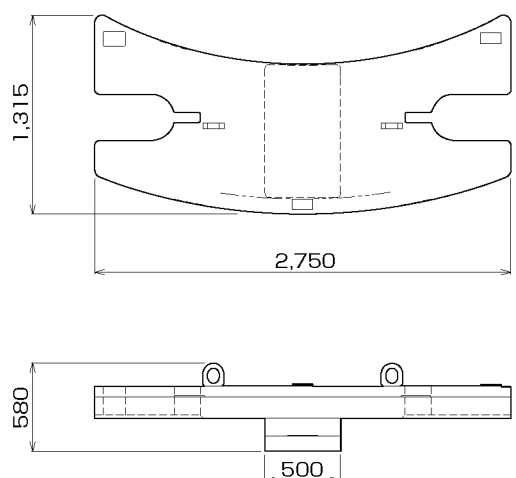

寸法・重量関係

■上部旋回体搬送状態（ブーム・旋回台、約28 t）

単位(mm)

リフト幅 2,992

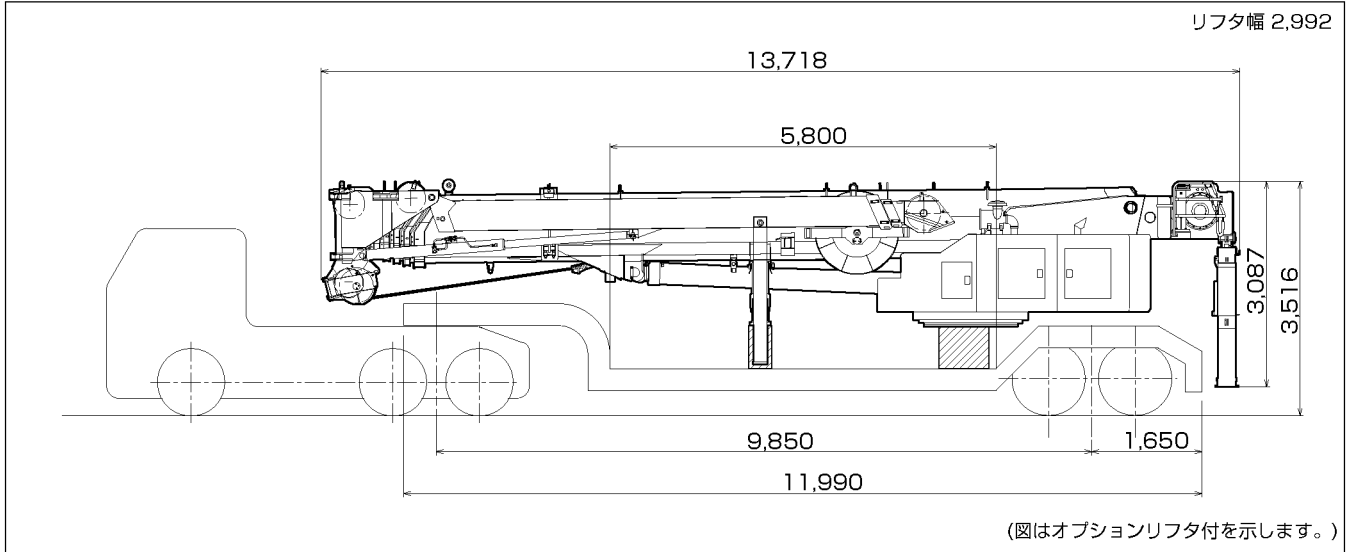

■カウンタウエイト搬送状態（約21 t）

単位(mm)

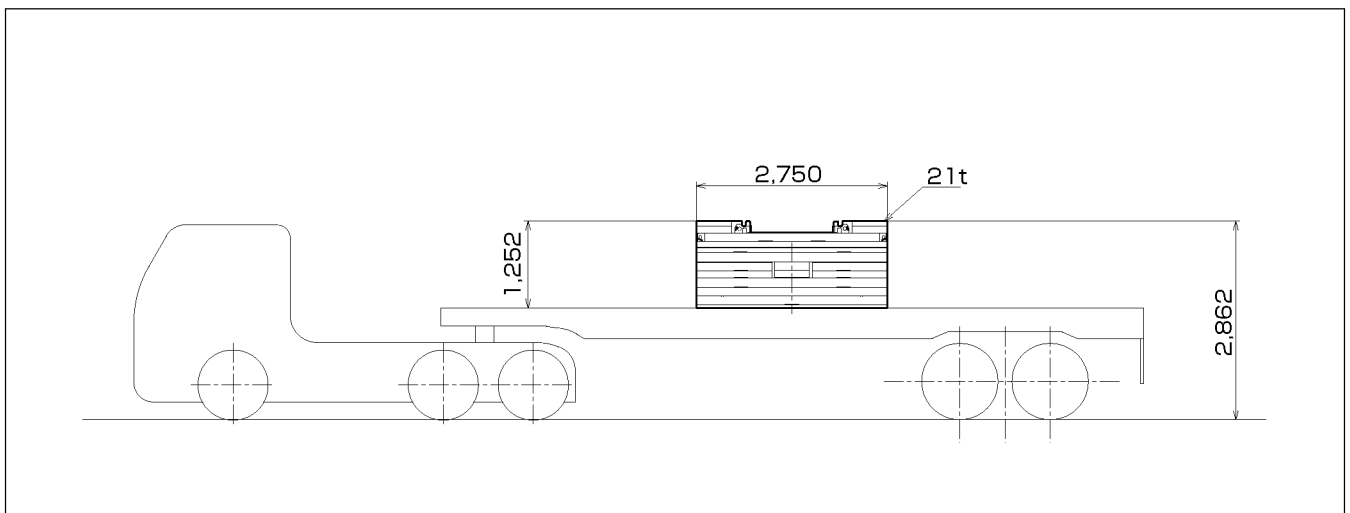

■キャリア公道走行状態（約24.63 t）

単位(mm)

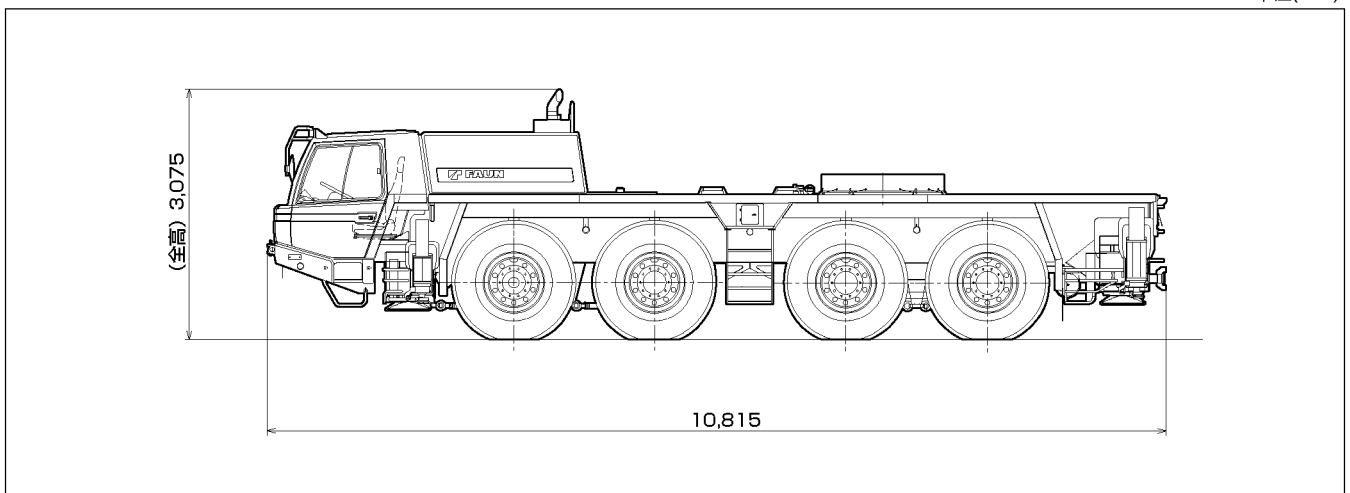

寸法・重量関係

■ 構内走行状態

単位 (mm)

縮尺1/100

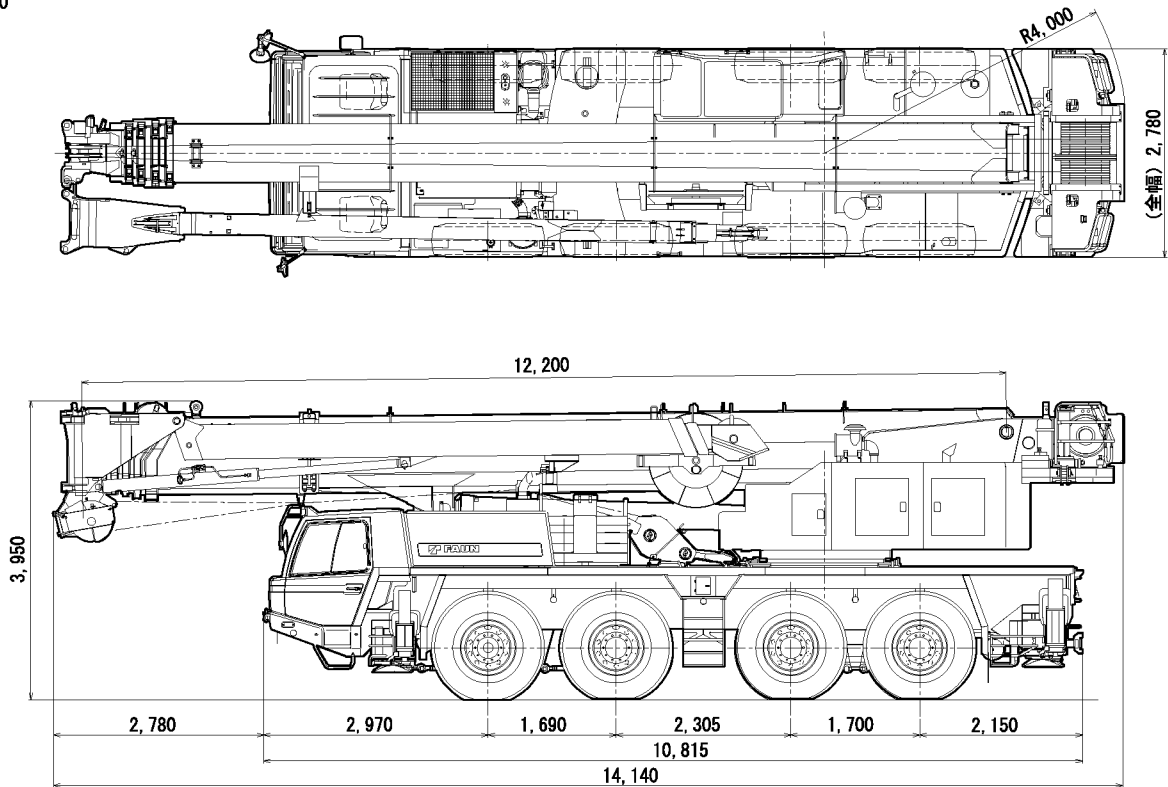

■ 公道走行状態

単位 (mm)

縮尺1/100

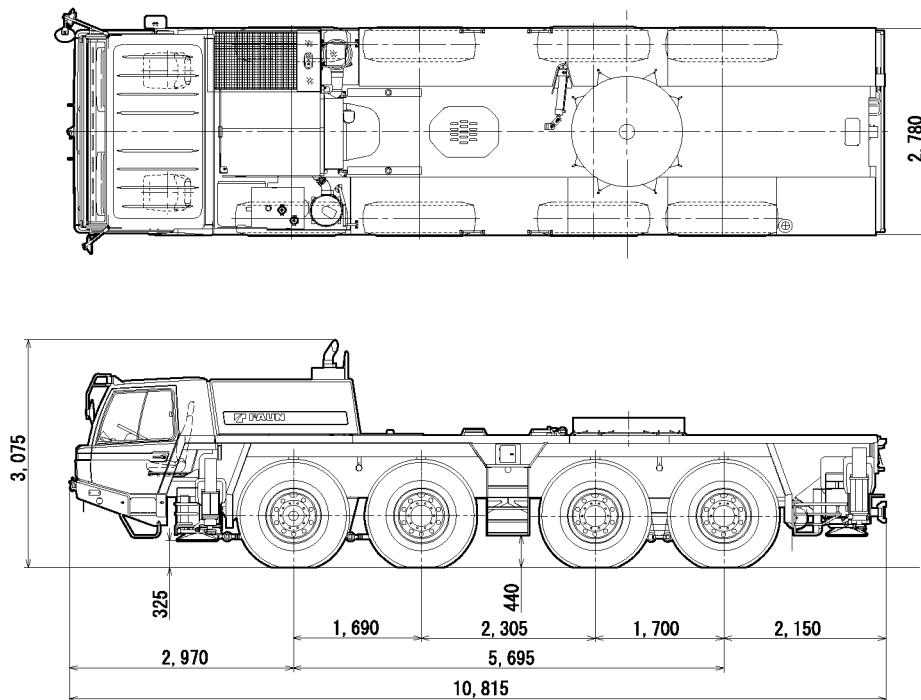

- (注意) 1. 本機は、公道を走行する場合には、旋回体及びブームを別送し、台車のみで走行しなければなりません。
2. 道路法による基本通行条件のA条件適合車です。

寸法・重量関係

単位 (mm)

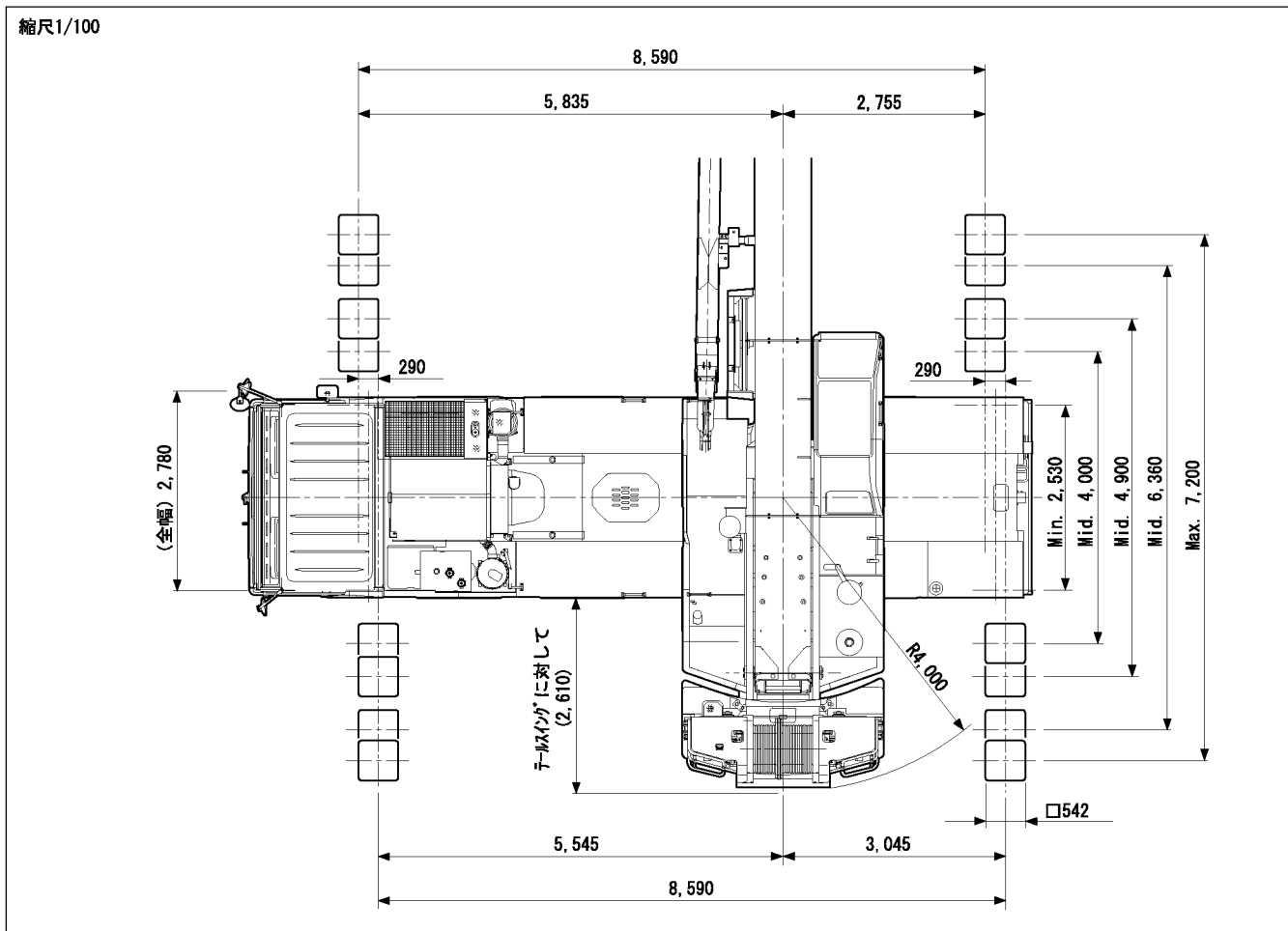

■ 最小直角通路幅

単位 (mm)

ノーマルステアリング (前4輪)

クランプステアリング (8輪)

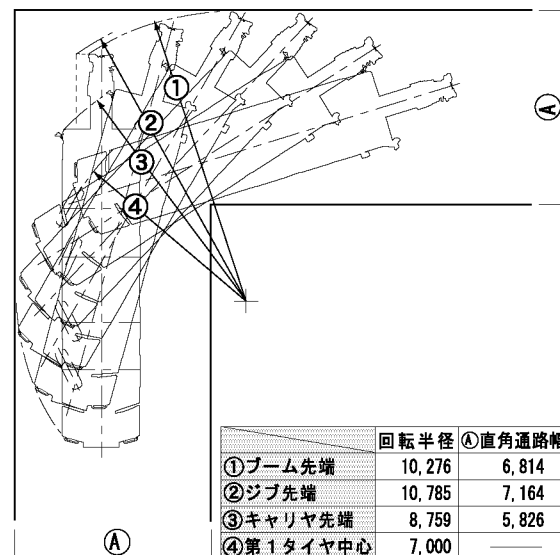
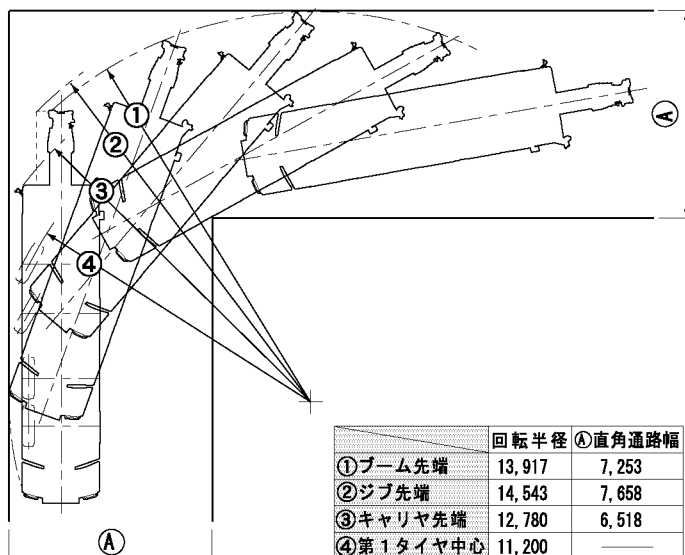

寸法・重量関係

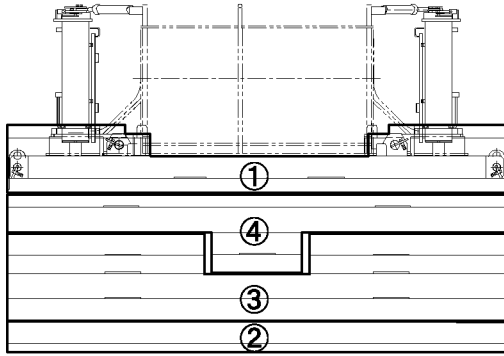

■カウンタウエイト質量表

ウエイト	質量
①	5t
②	4t
③	7t
④	5t

■カウンタウエイト組合せ表

ウエイト呼び	組合せ
21t	①+②+③+④
16t	①+②+③
9t	①+②
5t	①

■カウンタウエイト寸法図

単位 (mm)

① 固定ウエイト 5t

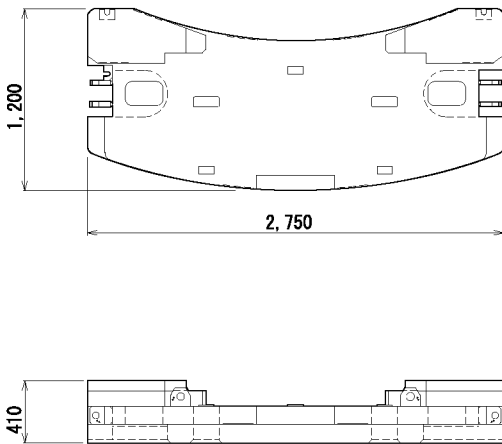

② STDウエイト 4t

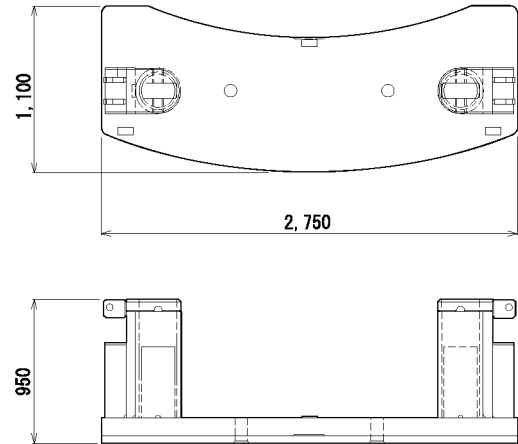

③ STDウエイト 7t

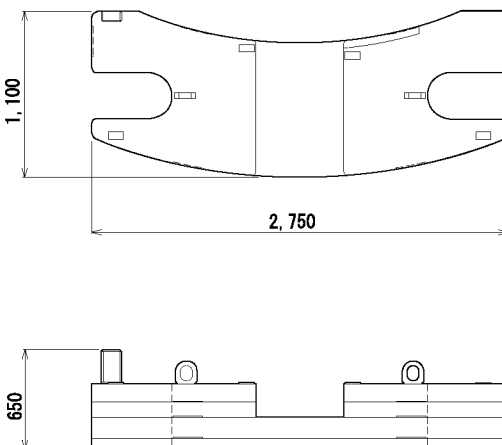

④ EXTウエイト 5t

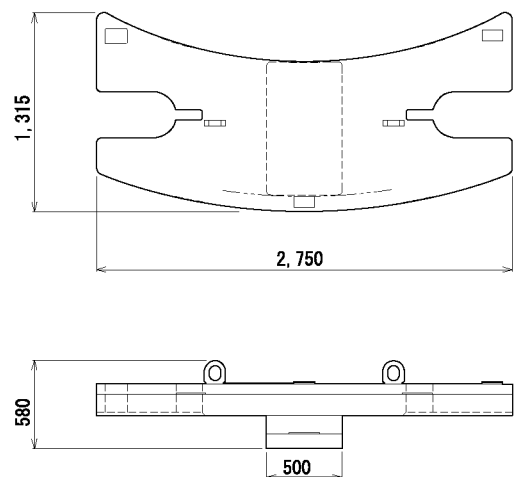

寸法・重量関係

■上部旋回体搬送状態（ブーム・旋回台，約28 t）

単位 (mm)

リフト幅 2,992

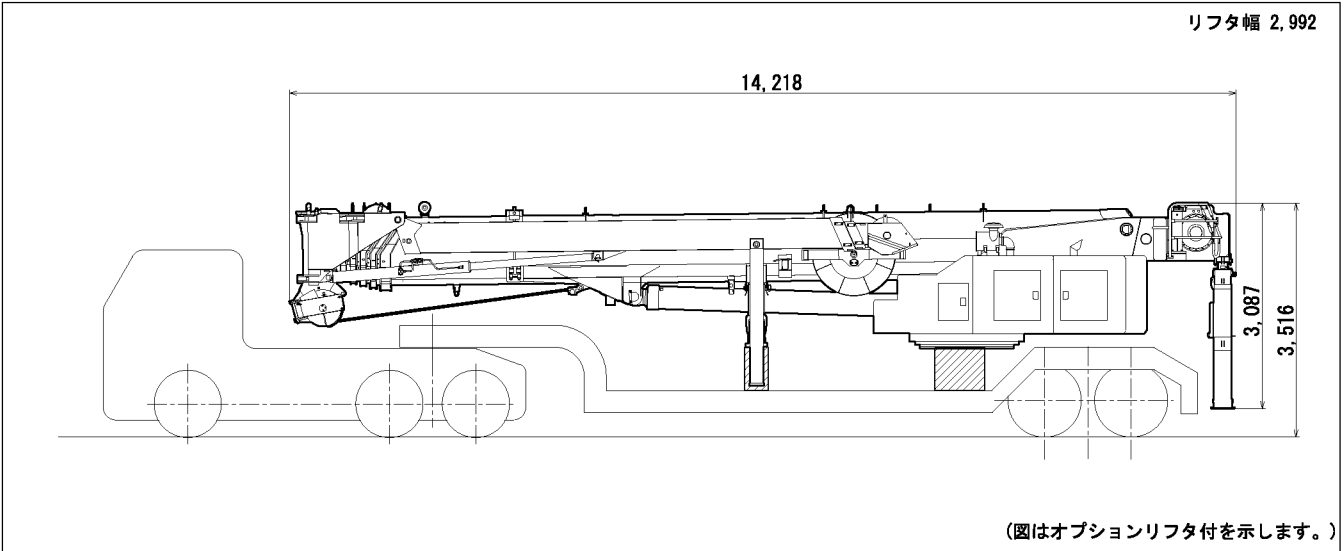

■カウンタウエイト搬送状態（約21 t）

単位 (mm)

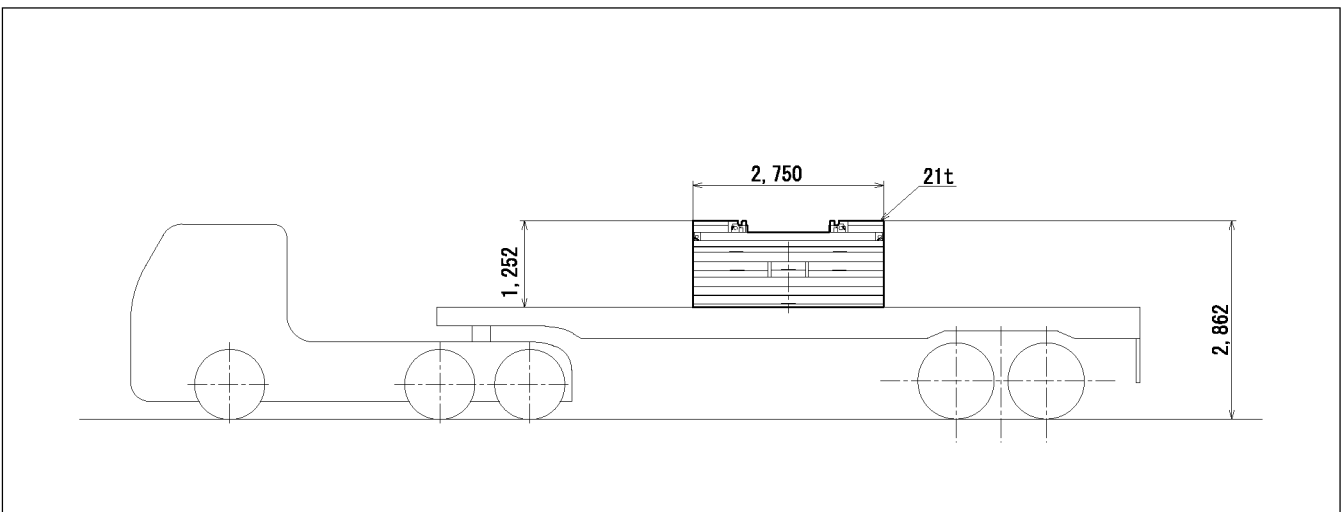

■キャリヤ公道走行状態（約24.63 t）

単位 (mm)

