

Mastertech

7200
7200FS

型式名 7200-2F

クローラクレーン

最大定格総荷重200t×5.0m

▶主要諸元	1
▶仕様とアタッチメント	1
クローラクレーン	
▶全体図	2
▶ブーム構成	3, 4
▶ロングブーム構成	4
▶作動範囲図	5
▶フック巻上限界	6
▶定格総荷重	6
▶主ブーム定格総荷重表 (117.1tウエイト)	7
▶補助シーブ定格総荷重表 (117.1tウエイト)	8
▶ロング主ブーム/ロング補助シーブ定格総荷重表 (117.1tウエイト)	9
▶主ブーム定格総荷重表 (75.1tウエイト)	10
▶補助シーブ定格総荷重表 (75.1tウエイト)	11
▶ロング主ブーム/ロング補助シーブ定格総荷重表 (75.1tウエイト)	12
ラフティングタワー	
▶全体図 (117.1tウエイト)	13
▶タワー構成/タワージブ構成	14
▶定格総荷重/フック巻上限界	15
▶タワー長さ36.6m (117.1tウエイト)	15
▶タワー長さ39.7m (117.1tウエイト)	16
▶タワー長さ42.7m (117.1tウエイト)	17
▶タワー長さ45.8m (117.1tウエイト)	18
▶タワー長さ48.8m (117.1tウエイト)	19, 20
▶タワー長さ51.9m (117.1tウエイト)	21, 22
▶タワー長さ54.9m (117.1tウエイト)	23, 24
▶タワー長さ58.0m (117.1tウエイト)	25, 26
▶タワー長さ61.0m (117.1tウエイト)	27, 28
▶タワー長さ64.1m (117.1tウエイト)	29, 30
アタッチメント	
▶クラムセル	31
台船搭載	
▶カウンタウエイト75.1 t (6枚) 装着 (カーボディウエイトなし)	32
▶クラムセル	32
▶分解時の寸法・質量	33, 34
▶標準装備品/オプション装備品	35

▶主要諸元 (型式：7200-2F)

項目	仕様	7200 (独立回路)		7200FS (合流回路)
		クレーン	ラフティングタワー	クレーン
最大つり上げ能力	t×m	200×5.0	25×18.0	200×5.0
		37.5×14.4 (ロング)		
ブーム(タワー)長さ	m	18.3~73.2	36.6~64.1	18.3~73.2
		73.2~91.4 (ロング)		
タワージブ長さ	m	—	27.4~51.8	—
最大タワー+タワージブ長さ	m	—	64.1+51.8	—
ロープ速度	主巻 巻上・巻下 m/min	*110~3	*110~3	*110/55
	補巻 巻上・巻下 m/min	*110~3	—	*110/55
	タワージブ起伏 巻上・巻下 m/min	—	*60~3	—
	ブーム(タワー)起伏 巻上・巻下 m/min	*(26~2)×2		
回転速度	min ⁻¹ {rpm}	2.2{2.2}		
走行速度	km/h	*1.1/0.7		
作業時質量(基本姿勢)	t	約208 ^{#1} /166 ^{#2}	約219 ^{#1} /177 ^{#2}	約208
接地圧	kPa{kgf/cm ² }	約114{1.16} ^{#1} / 91{0.93} ^{#2}	約120{1.22} ^{#1} / 97{0.99} ^{#2}	約114{1.16}
登坂能力(tanθ)	% (度)	30 (16.7)	—	30 (16.7)
定格ラインブル	kN{tf}	1本掛132{13.5}/ 多本掛123{12.5}	—	1本掛132{13.5}/ 多本掛123{12.5}
エンジン	名称	日野P11C		
	定格出力	kW/min ⁻¹ 247/2,000		
ワイヤロープ	主巻	mm φ28		
	補巻	mm φ28		
	ブーム(タワー)	mm φ22		
	ジブ(タワージブ)	mm —	mm φ22	mm —

各ロープ速度はドラム1層目での値です。

*印の速度は軽負荷の時の値であり、負荷により速度の変動があります。単位は国際単位系のSI表示で、{ }内は従来表示です。

※1 117.1tウエイト (カウンタウエイト8枚、カーボディウエイト2枚)

※2 75.1tウエイト (カウンタウエイト6枚、カーボディウエイトなし)

75.1tウエイトでの能力設定はオプションです。

▶仕様とアタッチメント

アタッチメント	仕様	7200 (独立回路)		7200FS (合流回路)
		クレーン	ラフティングタワー	クレーン
6.1m上部ブーム		◎	—	◎
4.6m中間テーパブーム*1		◎	—	◎
1.58mタワーキャップ		—	◎	—
7.6m下部ブーム(共用)		◎		
3.0m中間ブーム(ケーブルローラ付・共用)		○		
6.1m中間ブーム(ケーブルローラ付・共用)		○		
9.1m中間ブーム(ケーブルローラ付・共用)		○	◎	○
9.1mタワー専用中間ブーム*2		○兼用可	◎	—
9.1m上部タワージブ*3		△	◎	—
9.1m下部タワージブ		—	◎	—
3.0m中継ジブ*4		△	◎	—
3.0m中間タワージブ*5		△	○	—
6.1m中間タワージブ*5		△	◎	—
9.1m中間タワージブ*5		△	○	—
200tフック(8枚シーブ)		◎	—	◎
150tフック(100t兼用、6枚シーブ)		○	—	○
100tフック(4枚シーブ)		○	—	○
65tフック(3枚シーブ)		○	—	○
35tフック(1枚シーブ)		○	◎	○
13.5tボールフック		○		
補助シーブ		○	—	○
主巻ワイヤロープ(φ28×390m)		◎	—	◎
補巻ワイヤロープ(φ28×220m)		○	—	○
ブーム起伏ワイヤロープ(φ22×315m)		◎	—	◎
タワー主巻ワイヤロープ(φ28×390m)		—	◎	—
タワージブ起伏ワイヤロープ(φ22×185m)		—	◎	—
タワーブーム起伏ワイヤロープ(φ22×315m)		—	◎	—

◎印は基本仕様、○印は選択可能なアタッチメントを示します。

△はロングブームを構成する場合に必要なアタッチメントを示します。

*1 クローラクレーンの上部ブームまたはロングブームの3.0m中継ジブとセットで使用します。

*2 クローラクレーンの中間ブームに転用できます。

*3 ロングブーム仕様では上部ブームとして使用します。

*4 ロングブーム仕様では4.6mテーパブームと、ラフティングタワーでは下部タワージブとセットで使用します。

*5 ロングブーム仕様で中間ブームとして使用します。

クローラクレーン

▶全体図(単位: mm)

縮尺: 約 1/180

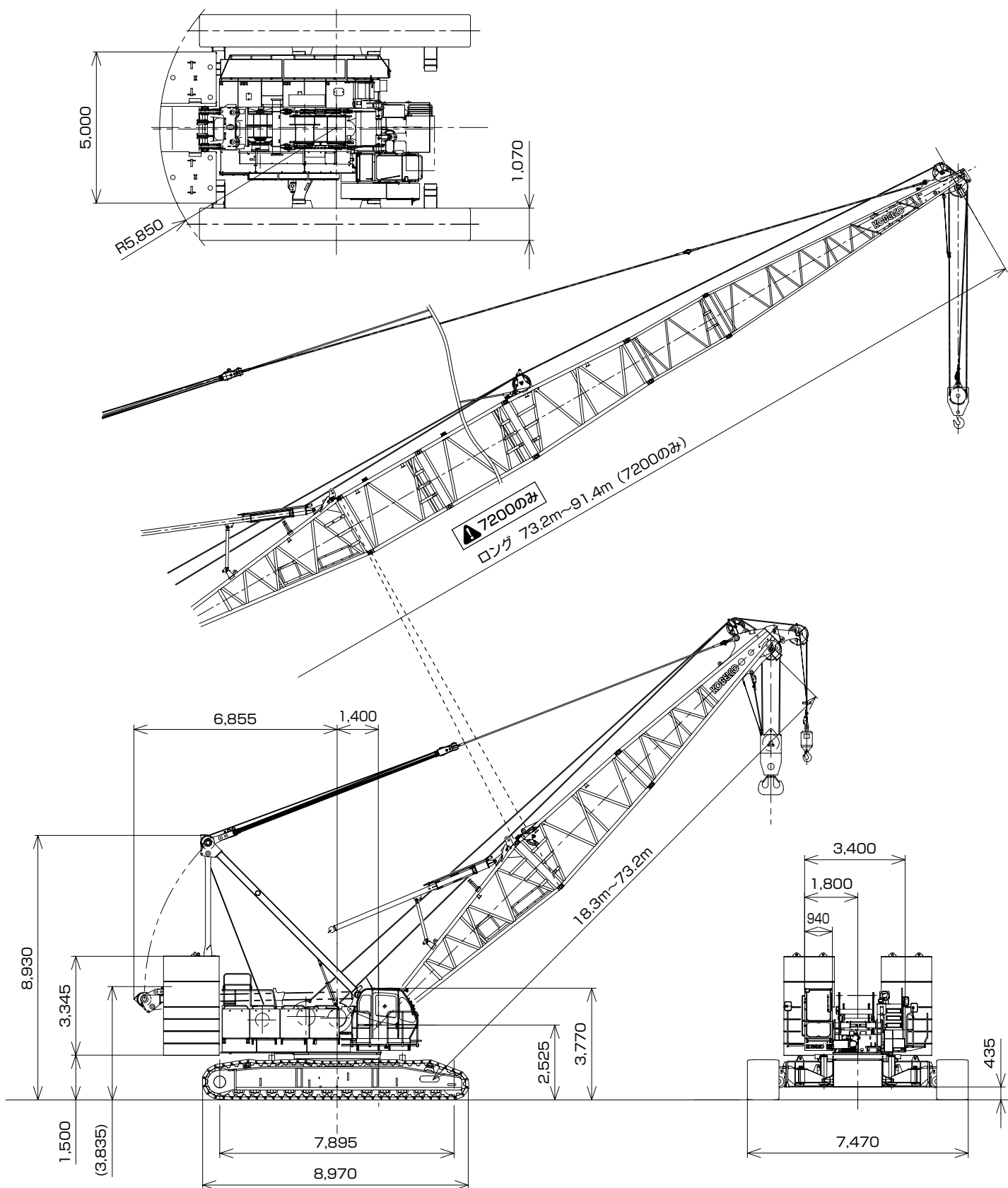

▶ブーム構成

▣ブーム構成 (9.1A中間ブーム不使用時)

- ※印は、これより短いブームの組立可能な構成を示します。
- 使用するガイラインの径はφ38mmです。

中間ブームの種類		
記号	ブーム長さ	備考
3.0	3.0m	ブーム
6.1	6.1m	ブーム
9.1	9.1m	ブーム
9.1A	9.1m	タワー専用ブーム (クレーンに兼用可能)
4.6T	4.6m	テーパブーム
3.0A	3.0m	中継ジブ
3.0	3.0m	タワージブ
6.1	6.1m	タワージブ
9.1	9.1m	タワージブ

ブーム長さ m (ft.)	ブーム構成 (9.1A中間ブーム不使用時)	ブーム長さ m (ft.)	ブーム構成 (9.1A中間ブーム不使用時)
18.3 (60)		48.8 (160)	*
21.3 (70)	*		
24.4 (80)	*	51.8 (170)	*
27.4 (90)	*	54.9 (180)	*
30.5 (100)	*	57.9 (190)	*
33.5 (110)	*	61.0 (200)	*
36.6 (120)	*	64.0 (210)	*
39.6 (130)	*	67.1 (220)	*
42.7 (140)	*	70.1 (230)	*
45.7 (150)	*	73.2 (240)	*

▶ブーム構成 (9.1A中間ブーム使用時) ▲7200のみ

- ※印は、これより短いブームの組立可能な構成を示します。
- 使用するガイラインの径はφ38mmです。
- 9.1Aはタワー用ですがクレーンにも転用できます。

ブーム長さ m (ft.)	ブーム構成 (9.1A中間ブーム使用時)	ブーム長さ m (ft.)	ブーム構成 (9.1A中間ブーム使用時)
18.3 (60)		48.8 (160)	*
21.3 (70)	*		
24.4 (80)	*	51.8 (170)	*
27.4 (90)	*	54.9 (180)	*
30.5 (100)	*	57.9 (190)	*
33.5 (110)	*	61.0 (200)	*
36.6 (120)	*	64.0 (210)	*
39.6 (130)	*	67.1 (220)	*
42.7 (140)	*	70.1 (230)	*
45.7 (150)	*	73.2 (240)	*

▶ロングブーム構成 ▲7200のみ

- ※印は、これより短いブームの組立可能な構成を示します。
- 使用するガイラインの径はφ38mmです。
- 9.1Aはタワー用ですがクレーンにも転用できます。

9.1Aを使用する場合は、右図のように組み替えてください。

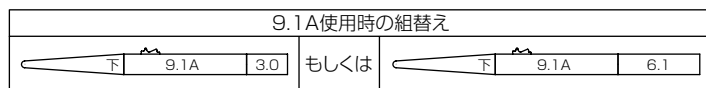

ブーム長さ m (ft.)	ブーム構成/ロング
73.2 (240)	
76.2 (250)	*
79.2 (260)	
	*
82.3 (270)	
	*
85.3 (280)	
88.4 (290)	
91.4 (300)	

▶作動範囲図

▶主ブーム

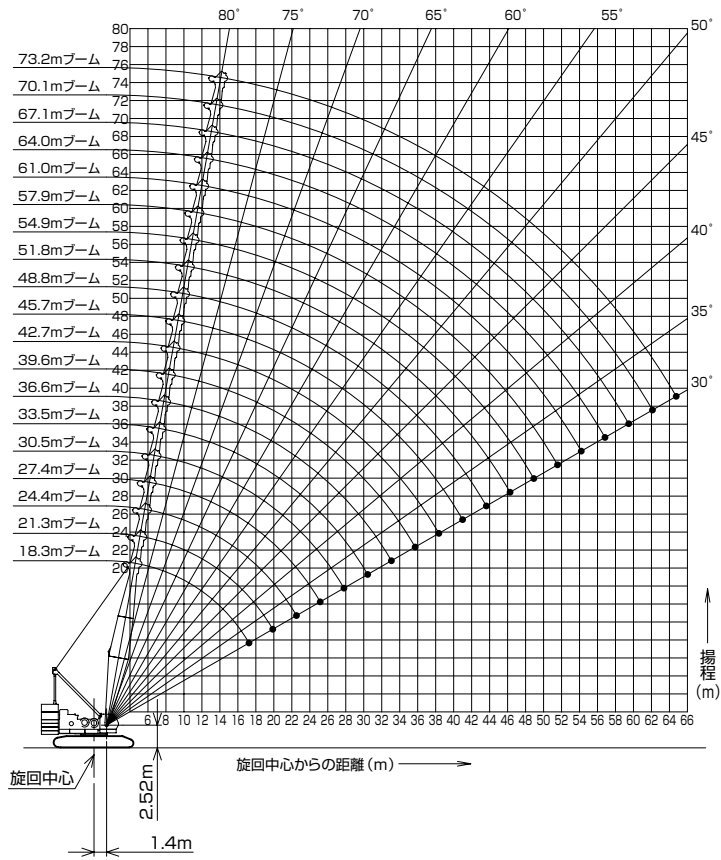

▶ロングブーム **7200のみ**

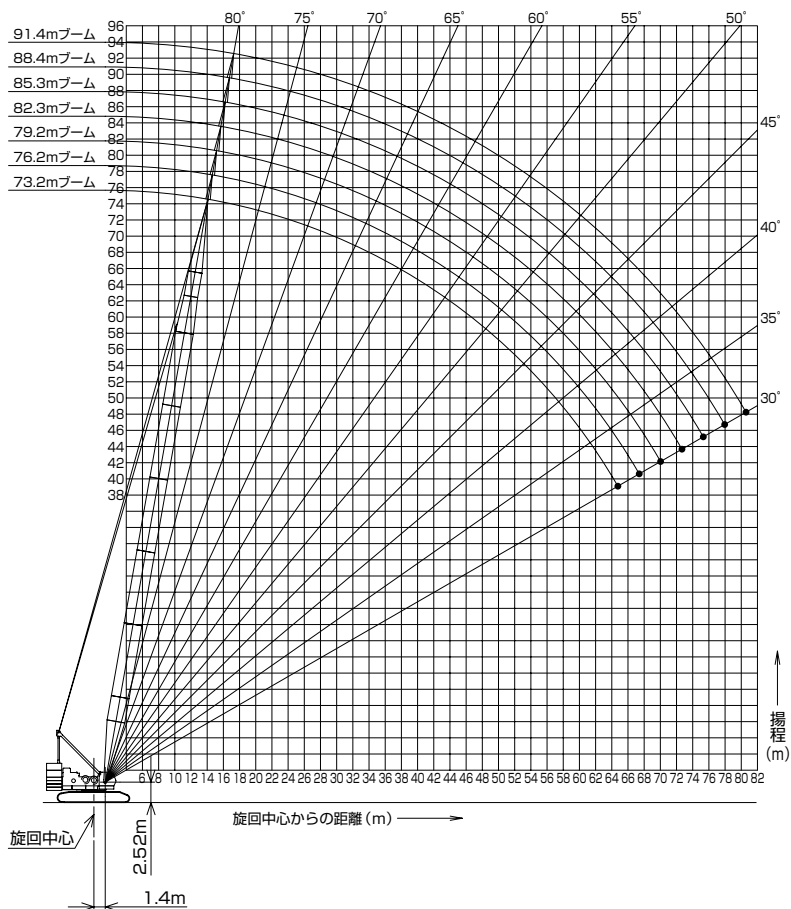

▶フック巻上限界 (単位:m)

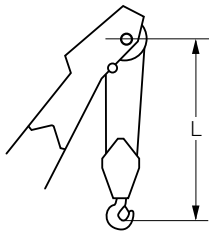

使用フック	L
200tフック	5.2
150tフック	5.8
100tフック	5.2
65tフック	5.0
35tフック	5.0

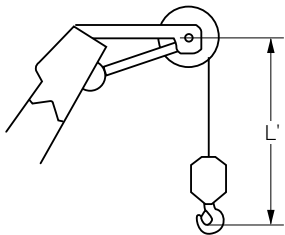

使用フック	L'
13.5tボールフック	5.0

▶定格総荷重

- 定格総荷重とは、水平堅土上における転倒荷重の78%以内で、フックブロック、玉掛用ワイヤロープ等のつり具の質量を含んだ値です。
- 作業半径とはクレーン旋回中心よりつり上荷重の重心までの水平距離を意味します。
- 実際につり上げ得る荷重は定格総荷重から（フック+玉掛用ワイヤロープ等のつり具）の質量を差し引いた値になります。
- 定格総荷重をつる場合にも風の影響、地盤の状態、作業速度その他安全作業に有害な状況がある時はオペレータは荷重の軽減、作業速度を遅くするなど状況に応じた判断をする責任があります。
- 表中の空欄の個所では作業を行うことができません。
- クレーン作業中には必ずガントリを最高位置に立ててください。
- すべてのブーム長さにおける中間ブームの構成は取扱説明書の指示を厳守してください。
- 主ブームに補助シーブを取り付けたままで主フックを使用する場合の定格総荷重は、主ブーム定格総荷重から、一律0.9t差し引いた値となります。ただし最小定格総荷重は2.4tとします。
- 補助シーブを装着できる主ブーム長さは、18.3m (60) ~ 73.2m (240)、ロングブーム長さは、73.2m (240) ~ 88.4m (290) です。
- △ 操作ミスなどによるつり荷の落下を防ぐため、クレーン作業では自由降下（フリーフォール）作業は行わないでください。

- 巻上げロープ巻掛本数に対する最大巻上荷重とフックの質量

フック 呼称	最大巻上荷重 (t)												フック 質量
	1本掛	2本掛	3本掛	4本掛	5本掛	6本掛	7本掛	8本掛	10本掛	12本掛	14本掛	16本掛	
200t	-	25.0	37.5	50.0	62.5	75.0	87.5	100.0	125.0	150.0	175.0	200.0	2.8t
150t	-	25.0	37.5	50.0	62.5	75.0	87.5	100.0	125.0	150.0	-	-	2.3t
100t	-	25.0	37.5	50.0	62.5	75.0	87.5	100.0	-	-	-	-	1.8t
65t	-	25.0	37.5	50.0	62.5	65.0	-	-	-	-	-	-	1.2t
35t	-	25.0	35.0	-	-	-	-	-	-	-	-	-	0.9t
13.5t ボールフック	13.5	-	-	-	-	-	-	-	-	-	-	-	0.45t

▶主ブーム定格総荷重表 (117.1tウエイト)

(単位:t)

ブーム長さ 作業半径 (m)	18.3	21.3	24.4	27.4	30.5	33.5	36.6	39.6	42.7	45.7	ブーム長さ 作業半径 (m)
5.0	200.0/5.0m	175.0/5.5m									5.0
6.0	189.6	175.0	150.0/6.0m	150.0/6.6m							6.0
7.0	163.9	163.5	150.0	150.0	125.0/7.1m	125.0/7.6m					7.0
8.0	144.3	143.9	143.5	143.3	125.0	125.0	100.0/8.2m	100.0/8.7m			8.0
9.0	128.8	128.4	128.0	127.8	125.0	123.1	100.0	100.0	98.8/9.2m	87.5/9.7m	9.0
10.0	116.3	115.8	115.5	115.2	114.8	114.6	100.0	100.0	96.7	87.5	10.0
12.0	90.6	90.4	90.2	90.0	89.8	89.6	89.6	89.4	89.2	85.3	12.0
14.0	73.0	72.7	72.5	72.3	72.1	71.9	71.8	71.6	71.4	71.3	14.0
16.0	61.0	60.7	60.4	60.2	60.0	59.8	59.7	59.4	59.2	59.1	16.0
18.0	52.9/17.4m	51.9	51.6	51.4	51.2	50.9	50.8	50.5	50.3	50.2	18.0
20.0		45.3	45.0	44.7	44.5	44.2	44.1	43.8	43.6	43.4	20.0
22.0		45.1/20.1m	39.7	39.5	39.2	39.0	38.8	38.5	38.3	38.1	22.0
24.0			38.2/22.7m	35.3	35.0	34.7	34.6	34.3	34.0	33.9	24.0
26.0				32.9/25.4m	31.5	31.2	31.1	30.8	30.5	30.3	26.0
28.0					28.6/28.0m	28.3	28.2	27.8	27.6	27.4	28.0
30.0						25.9	25.7	25.4	25.1	24.9	30.0
32.0						25.2/30.6m	23.6	23.2	23.0	22.8	32.0
34.0							22.4/33.3m	21.4	21.1	20.9	34.0
36.0								19.9/35.9m	19.5	19.3	36.0
38.0									18.1	17.9	38.0
40.0									17.8/38.6m	16.6	40.0
42.0										15.9/41.2m	42.0

※表中の太線で囲まれた部分は、ブーム等の強度によって定められた値です。

(単位:t)

ブーム長さ 作業半径 (m)	48.8	51.8	54.9	57.9	61.0	64.0	67.1	70.1	73.2	ブーム長さ 作業半径 (m)
10.0	75.0/10.3m	75.0/10.8m	71.6/11.3m	62.5/11.9m						10.0
12.0	75.0	75.0	70.5	62.5	61.0/12.4m	50.0/12.9m	50.0/13.4m			12.0
14.0	71.1	70.7	66.6	61.9	58.3	50.0	50.0	47.5/14.0m	37.5/14.5m	14.0
16.0	58.9	58.7	58.4	58.3	54.9	50.0	47.7	44.8	37.5	16.0
18.0	50.0	49.8	49.5	49.5	49.2	48.1	45.1	42.3	37.5	18.0
20.0	43.2	43.0	42.8	42.7	42.4	42.3	42.2	40.3	35.2	20.0
22.0	37.9	37.7	37.5	37.3	37.1	37.0	36.8	36.5	33.2	22.0
24.0	33.6	33.4	33.2	33.0	32.8	32.7	32.4	32.2	31.3	24.0
26.0	30.1	29.9	29.6	29.5	29.2	29.1	28.9	28.6	28.5	26.0
28.0	27.2	26.9	26.7	26.5	26.3	26.2	25.9	25.6	25.6	28.0
30.0	24.7	24.4	24.2	24.0	23.7	23.6	23.3	23.1	23.0	30.0
32.0	22.5	22.3	22.0	21.8	21.6	21.5	21.2	20.9	20.9	32.0
34.0	20.7	20.4	20.2	19.9	19.7	19.6	19.3	19.0	19.0	34.0
36.0	19.0	18.8	18.5	18.3	18.1	17.9	17.6	17.4	17.3	36.0
38.0	17.6	17.3	17.1	16.9	16.6	16.5	16.2	15.9	15.8	38.0
40.0	16.3	16.1	15.8	15.6	15.3	15.2	14.9	14.6	14.5	40.0
42.0	15.2	14.9	14.6	14.4	14.2	14.0	13.7	13.5	13.4	42.0
44.0	14.3/43.8m	13.9	13.6	13.4	13.1	13.0	12.7	12.4	12.3	44.0
46.0		13.0	12.7	12.4	12.2	12.0	11.7	11.5	11.4	46.0
48.0		12.8/46.5m	11.9	11.6	11.3	11.2	10.9	10.6	10.5	48.0
50.0			11.5/49.1m	10.8	10.6	10.4	10.1	9.8	9.7	50.0
52.0				10.2/51.8m	9.9	9.7	9.4	9.1	9.0	52.0
54.0					9.2	9.0	8.7	8.4	8.3	54.0
56.0					9.1/54.4m	8.4	8.1	7.8	7.7	56.0
58.0						8.2/57.0m	7.6	7.3	7.1	58.0
60.0							7.1/59.7m	6.7	6.4	60.0
62.0								6.1	5.9	62.0
64.0								6.0/62.3m	5.3	64.0
66.0									5.1/65.0m	66.0

※表中の太線で囲まれた部分は、ブーム等の強度によって定められた値です。

▶ 補助シーブ定格総荷重表 (117.1tウエイト、主ブームにフックなし)

(単位:t)

ブーム長さ 作業半径 (m)	18.3	21.3	24.4	27.4	30.5	33.5	36.6	39.6	42.7	45.7	ブーム長さ 作業半径 (m)
5.0	13.5/5.7m										5.0
6.0	13.5	13.5/6.3m	13.5/6.8m								6.0
7.0	13.5	13.5	13.5	13.5/7.3m	13.5/7.8m						7.0
8.0	13.5	13.5	13.5	13.5	13.5	13.5/8.4m	13.5/8.9m				8.0
9.0	13.5	13.5	13.5	13.5	13.5	13.5	13.5	13.5/9.4m			9.0
10.0	13.5	13.5	13.5	13.5	13.5	13.5	13.5	13.5	13.5/10.0m	13.5/10.5m	10.0
12.0	13.5	13.5	13.5	13.5	13.5	13.5	13.5	13.5	13.5	13.5	12.0
14.0	13.5	13.5	13.5	13.5	13.5	13.5	13.5	13.5	13.5	13.5	14.0
16.0	13.5	13.5	13.5	13.5	13.5	13.5	13.5	13.5	13.5	13.5	16.0
18.0	13.5	13.5	13.5	13.5	13.5	13.5	13.5	13.5	13.5	13.5	18.0
20.0	13.5/18.7m	13.5	13.5	13.5	13.5	13.5	13.5	13.5	13.5	13.5	20.0
22.0		13.5/21.4m	13.5	13.5	13.5	13.5	13.5	13.5	13.5	13.5	22.0
24.0			13.5/24.0m	13.5	13.5	13.5	13.5	13.5	13.5	13.5	24.0
26.0				13.5	13.5	13.5	13.5	13.5	13.5	13.5	26.0
28.0				13.5/26.7m	13.5	13.5	13.5	13.5	13.5	13.5	28.0
30.0					13.5/29.3m	13.5	13.5	13.5	13.5	13.5	30.0
32.0						13.5/32.0m	13.5	13.5	13.5	13.5	32.0
34.0							13.5	13.5	13.5	13.5	34.0
36.0							13.5/34.6m	13.5	13.5	13.5	36.0
38.0								13.5/37.2m	13.5	13.5	38.0
40.0									13.5/39.9m	13.5	40.0
42.0										13.5	42.0
44.0										13.5/42.5m	44.0

※表中の太線で囲まれた部分は、ブーム等の強度によって定められた値です。

(単位:t)

ブーム長さ 作業半径 (m)	48.8	51.8	54.9	57.9	61.0	64.0	67.1	70.1	73.2	ブーム長さ 作業半径 (m)
10.0	13.5/11.0m									10.0
12.0	13.5	13.5/11.5m	13.5/12.1m	13.5/12.6m	13.5/13.1m	13.5/13.7m				12.0
14.0	13.5	13.5	13.5	13.5	13.5	13.5	13.5/14.2m	13.5/14.7m	13.5/15.3m	14.0
16.0	13.5	13.5	13.5	13.5	13.5	13.5	13.5	13.5	13.5	16.0
18.0	13.5	13.5	13.5	13.5	13.5	13.5	13.5	13.5	13.5	18.0
20.0	13.5	13.5	13.5	13.5	13.5	13.5	13.5	13.5	13.5	20.0
22.0	13.5	13.5	13.5	13.5	13.5	13.5	13.5	13.5	13.5	22.0
24.0	13.5	13.5	13.5	13.5	13.5	13.5	13.5	13.5	13.5	24.0
26.0	13.5	13.5	13.5	13.5	13.5	13.5	13.5	13.5	13.5	26.0
28.0	13.5	13.5	13.5	13.5	13.5	13.5	13.5	13.5	13.5	28.0
30.0	13.5	13.5	13.5	13.5	13.5	13.5	13.5	13.5	13.5	30.0
32.0	13.5	13.5	13.5	13.5	13.5	13.5	13.5	13.5	13.5	32.0
34.0	13.5	13.5	13.5	13.5	13.5	13.5	13.5	13.5	13.5	34.0
36.0	13.5	13.5	13.5	13.5	13.5	13.5	13.5	13.5	13.5	36.0
38.0	13.5	13.5	13.5	13.5	13.5	13.5	13.5	13.5	13.5	38.0
40.0	13.5	13.5	13.5	13.5	13.5	13.5	13.5	13.5	13.5	40.0
42.0	13.5	13.5	13.5	13.5	13.5	13.5	13.4	13.2	13.1	42.0
44.0	13.5	13.5	13.3	13.1	12.8	12.7	12.4	12.1	12.0	44.0
46.0	13.2/45.1m	12.7	12.4	12.1	11.9	11.7	11.4	11.2	11.1	46.0
48.0		11.9/47.8m	11.6	11.3	11.0	10.9	10.6	10.3	10.2	48.0
50.0			10.8	10.5	10.3	10.1	9.8	9.5	9.4	50.0
52.0			10.6/50.4m	9.7	9.6	9.4	9.1	8.8	8.7	52.0
54.0				9.3/53.1m	8.9	8.7	8.4	8.1	8.0	54.0
56.0					8.3/55.7m	8.1	7.8	7.5	7.4	56.0
58.0						7.5	7.3	7.0	6.8	58.0
60.0						7.4/58.3m	6.8	6.4	6.1	60.0
62.0							6.6/61.0m	5.8	5.6	62.0
64.0								5.3/63.6m	5.0	64.0
66.0									4.4	66.0
68.0									4.3/66.3m	68.0

※表中の太線で囲まれた部分は、ブーム等の強度によって定められた値です。

▶ ロング主ブーム定格総荷重表(117.1tウエイト) 

(単位:t)

ブーム長さ 作業半径(m)	73.2	76.2	79.2	82.3	85.3	88.4	91.4	ブーム長さ 作業半径(m)
14.0	37.5/14.4m	34.5/14.9m	32.6/15.4m					14.0
16.0	36.0	33.5	32.1	31.2/16.0m	25.0/16.5m	25.0/17.0m	21.5/17.6m	16.0
18.0	34.4	31.9	30.6	29.6	25.0	25.0	21.2	18.0
20.0	32.9	30.4	29.1	28.2	25.0	24.1	20.0	20.0
22.0	31.6	29.1	27.9	26.9	25.0	23.0	18.9	22.0
24.0	30.4	27.9	26.8	25.7	24.2	22.0	17.8	24.0
26.0	28.8	26.5	25.6	24.6	23.2	21.1	16.9	26.0
28.0	26.2	25.2	24.5	23.6	22.3	20.1	16.0	28.0
30.0	23.8	23.6	23.3	22.6	21.1	19.1	15.3	30.0
32.0	21.8	21.7	21.6	21.5	19.9	18.1	14.5	32.0
34.0	19.9	19.9	19.7	19.7	18.7	17.1	13.8	34.0
36.0	18.3	18.3	18.2	18.1	17.7	16.1	13.1	36.0
38.0	16.9	16.8	16.7	16.7	16.5	15.1	12.5	38.0
40.0	15.6	15.6	15.4	15.4	15.4	14.2	11.8	40.0
42.0	14.5	14.5	14.3	14.3	14.3	13.4	11.2	42.0
44.0	13.4	13.4	13.2	13.2	13.2	12.5	10.7	44.0
46.0	12.5	12.5	12.3	12.3	12.2	11.8	10.2	46.0
48.0	11.6	11.5	11.4	11.4	11.3	11.1	9.8	48.0
50.0	10.7	10.7	10.6	10.5	10.5	10.3	9.4	50.0
52.0	10.0	10.0	9.9	9.8	9.8	9.6	8.9	52.0
54.0	9.3	9.3	9.1	9.1	9.0	9.0	8.5	54.0
56.0	8.6	8.6	8.5	8.4	8.4	8.4	7.8	56.0
58.0	8.0	8.0	7.8	7.8	7.7	7.7	7.2	58.0
60.0	7.4	7.3	7.2	7.2	7.1	7.1	6.7	60.0
62.0	6.8	6.7	6.7	6.6	6.6	6.6	6.1	62.0
64.0	6.3	6.1	6.1	6.1	6.0	6.0	5.6	64.0
66.0	6.1/64.9m	5.6	5.6	5.6	5.6	5.6	5.1	66.0
68.0		5.4/67.5m	5.3	5.2	5.2	5.2	4.6	68.0
70.0			4.8	4.7	4.7	4.7	4.1	70.0
72.0			4.8/70.2m	4.3	4.3	4.3	3.6	72.0
74.0				4.2/72.8m	3.9	3.9	3.1	74.0
76.0					3.7/74.5m	3.5	2.6/76.0m	76.0
78.0						3.2		78.0
80.0						3.2/78.1m		80.0

※表中の太線で囲まれた部分は、ブーム等の強度によって定められた値です。

▶ ロング補助シーブ定格総荷重表(117.1tウエイト、主ブームにフックなし) 

(単位:t)

ブーム長さ 作業半径(m)	73.2	76.2	79.2	82.3	85.3	88.4	ブーム長さ 作業半径(m)
14.0	13.5/15.1m	13.5/15.7m					14.0
16.0	13.5	13.5	13.5/16.2m	13.5/16.7m	13.5/17.3m	13.5/17.8m	16.0
18.0	13.5	13.5	13.5	13.5	13.5	13.5	18.0
20.0	13.5	13.5	13.5	13.5	13.5	13.5	20.0
22.0	13.5	13.5	13.5	13.5	13.5	13.5	22.0
24.0	13.5	13.5	13.5	13.5	13.5	13.5	24.0
26.0	13.5	13.5	13.5	13.5	13.5	13.5	26.0
28.0	13.5	13.5	13.5	13.5	13.5	13.5	28.0
30.0	13.5	13.5	13.5	13.5	13.5	13.5	30.0
32.0	13.5	13.5	13.5	13.5	13.5	13.5	32.0
34.0	13.5	13.5	13.5	13.5	13.5	13.5	34.0
36.0	13.5	13.5	13.5	13.5	13.5	13.5	36.0
38.0	13.5	13.5	13.5	13.5	13.5	13.5	38.0
40.0	13.5	13.5	13.5	13.5	13.5	13.5	40.0
42.0	13.5	13.5	13.5	13.5	13.5	13.1	42.0
44.0	13.1	13.1	12.9	12.9	12.9	12.2	44.0
46.0	12.2	12.2	12.0	12.0	11.9	11.5	46.0
48.0	11.3	11.2	11.1	11.1	11.0	10.8	48.0
50.0	10.4	10.4	10.3	10.2	10.2	10.0	50.0
52.0	9.7	9.7	9.6	9.5	9.5	9.3	52.0
54.0	9.0	9.0	8.8	8.8	8.7	8.7	54.0
56.0	8.3	8.3	8.2	8.1	8.1	8.1	56.0
58.0	7.7	7.7	7.5	7.5	7.4	7.4	58.0
60.0	7.1	7.0	6.9	6.9	6.8	6.8	60.0
62.0	6.5	6.4	6.4	6.3	6.3	6.3	62.0
64.0	6.0	5.8	5.8	5.8	5.7	5.7	64.0
66.0	5.5/66.0m	5.3	5.3	5.3	5.3	5.3	66.0
68.0		4.8	5.0	4.9	4.9	4.9	68.0
70.0		4.6/68.7m	4.5	4.4	4.4	4.4	70.0
72.0			4.2/71.3m	4.0	4.0	4.0	72.0
74.0				3.6/74.0m	3.6	3.6	74.0
76.0					3.2	3.2	76.0
78.0					3.1/76.6m	2.9/78.0m	78.0

※表中の太線で囲まれた部分は、ブーム等の強度によって定められた値です。

▶主ブーム定格総荷重表(75.1tウエイト)

(単位:t)

ブーム長さ 作業半径 (m)	18.3	21.3	24.4	27.4	30.5	33.5	36.6	39.6	42.7	45.7	ブーム長さ 作業半径 (m)
5.0	200.0/5.0m	175.0/5.5m									5.0
6.0	178.3	175.0	150.0/6.0m	150.0/6.6m							6.0
7.0	154.2	153.8	150.0	150.0	125.0/7.1m	125.0/7.6m					7.0
8.0	133.1	133.0	132.9	132.8	125.0	125.0	100.0/8.2m	100.0/8.7m			8.0
9.0	109.1	108.9	108.8	108.7	108.6	108.4	100.0	100.0	98.8/9.2m	87.5/9.7m	9.0
10.0	92.2	92.1	91.9	91.8	91.6	91.5	91.5	91.2	91.1	87.5	10.0
12.0	70.2	69.9	69.8	69.6	69.4	69.2	69.2	68.9	68.7	68.6	12.0
14.0	56.4	56.1	55.9	55.7	55.5	55.3	55.2	55.0	54.8	54.6	14.0
16.0	47.0	46.7	46.4	46.2	46.0	45.8	45.7	45.4	45.2	45.1	16.0
18.0	41.9/17.4m	39.8	39.5	39.3	39.1	38.8	38.8	38.4	38.2	38.1	18.0
20.0		34.7	34.3	34.1	33.8	33.6	33.5	33.2	32.9	32.8	20.0
22.0		34.5/20.1m	30.2	30.0	29.7	29.4	29.3	29.0	28.8	28.6	22.0
24.0			29.0/22.7m	26.7	26.4	26.1	26.0	25.7	25.4	25.3	24.0
26.0				24.8/25.4m	23.7	23.4	23.3	22.9	22.7	22.5	26.0
28.0					21.4/28.0m	21.1	21.0	20.6	20.4	20.2	28.0
30.0						19.2	19.1	18.7	18.4	18.2	30.0
32.0						18.7/30.6m	17.4	17.0	16.8	16.6	32.0
34.0							16.5/33.3m	15.6	15.3	15.1	34.0
36.0								14.4/35.9m	14.1	13.9	36.0
38.0									13.0	12.8	38.0
40.0									12.7/38.6m	11.8	40.0
42.0										11.3/41.2m	42.0

※表中の太線で囲まれた部分は、ブーム等の強度によって定められた値です。

※75.1tウエイトでの能力設定はオプションです。

(単位:t)

ブーム長さ 作業半径 (m)	48.8	51.8	54.9	57.9	61.0	64.0	67.1	70.1	73.2	ブーム長さ 作業半径 (m)
10.0	75.0/10.3m	75.0/10.8m	71.6/11.3m	62.5/11.9m						10.0
12.0	68.5	68.3	68.1	62.5	61.0/12.4m	60.0/12.9m	50.0/13.4m			12.0
14.0	54.5	54.3	54.1	54.0	53.8	50.0	50.0	47.5/14.0m	37.5/14.5m	14.0
16.0	44.9	44.7	44.5	44.3	44.1	44.0	43.8	43.6	37.5	16.0
18.0	37.9	37.7	37.5	37.3	37.1	37.0	36.8	36.5	36.5	18.0
20.0	32.6	32.4	32.1	32.0	31.8	31.7	31.4	31.2	31.1	20.0
22.0	28.4	28.2	28.0	27.8	27.6	27.5	27.2	27.0	26.9	22.0
24.0	25.1	24.8	24.6	24.4	24.2	24.1	23.8	23.6	23.5	24.0
26.0	22.3	22.1	21.8	21.6	21.4	21.3	21.0	20.8	20.7	26.0
28.0	20.0	19.7	19.5	19.3	19.1	19.0	18.7	18.4	18.4	28.0
30.0	18.0	17.8	17.5	17.3	17.1	17.0	16.7	16.5	16.4	30.0
32.0	16.3	16.1	15.8	15.6	15.4	15.3	15.0	14.7	14.7	32.0
34.0	14.9	14.6	14.4	14.2	13.9	13.8	13.5	13.3	13.2	34.0
36.0	13.6	13.3	13.1	12.9	12.6	12.5	12.2	12.0	11.9	36.0
38.0	12.5	12.2	11.9	11.7	11.5	11.3	11.0	10.8	10.7	38.0
40.0	11.5	11.2	10.9	10.7	10.5	10.3	10.0	9.8	9.7	40.0
42.0	10.6	10.3	10.1	9.8	9.6	9.4	9.1	8.9	8.8	42.0
44.0	9.9/43.8m	9.5	9.3	9.0	8.8	8.6	8.3	8.0	7.9	44.0
46.0		8.8	8.5	8.3	8.0	7.9	7.6	7.3	7.1	46.0
48.0		8.7/46.5m	7.9	7.6	7.4	7.2	6.8	6.5	6.3	48.0
50.0			7.6/49.1m	7.0	6.8	6.5	6.1	5.7	5.6	50.0
52.0				6.6/51.8m	6.1	5.9	5.4	5.1	4.9	52.0
54.0					5.5	5.3	4.8	4.5	4.3	54.0
56.0					5.4/54.4m	4.7	4.3	3.9	3.7	56.0
58.0						4.5/57.0m	3.8	3.4	3.2	58.0
60.0							3.4/59.7m	2.9	2.7/60.0m	60.0
62.0								2.5		62.0
64.0								2.4/62.3m		64.0

※表中の太線で囲まれた部分は、ブーム等の強度によって定められた値です。

※75.1tウエイトでの能力設定はオプションです。

▶ 補助シーブ定格総荷重表 (75.1tウエイト、主ブームにフックなし)

(単位:t)

ブーム長さ 作業半径 (m)	18.3	21.3	24.4	27.4	30.5	33.5	36.6	39.6	42.7	45.7	ブーム長さ 作業半径 (m)
5.0	13.5/5.7m										5.0
6.0	13.5	13.5/6.3m	13.5/6.8m								6.0
7.0	13.5	13.5	13.5	13.5/7.3m	13.5/7.8m						7.0
8.0	13.5	13.5	13.5	13.5	13.5	13.5/8.4m	13.5/8.9m				8.0
9.0	13.5	13.5	13.5	13.5	13.5	13.5	13.5	13.5/9.4m			9.0
10.0	13.5	13.5	13.5	13.5	13.5	13.5	13.5	13.5	13.5/10.0m	13.5/10.5m	10.0
12.0	13.5	13.5	13.5	13.5	13.5	13.5	13.5	13.5	13.5	13.5	12.0
14.0	13.5	13.5	13.5	13.5	13.5	13.5	13.5	13.5	13.5	13.5	14.0
16.0	13.5	13.5	13.5	13.5	13.5	13.5	13.5	13.5	13.5	13.5	16.0
18.0	13.5	13.5	13.5	13.5	13.5	13.5	13.5	13.5	13.5	13.5	18.0
20.0	13.5/18.7m	13.5	13.5	13.5	13.5	13.5	13.5	13.5	13.5	13.5	20.0
22.0		13.5/21.4m	13.5	13.5	13.5	13.5	13.5	13.5	13.5	13.5	22.0
24.0			13.5/24.0m	13.5	13.5	13.5	13.5	13.5	13.5	13.5	24.0
26.0				13.5	13.5	13.5	13.5	13.5	13.5	13.5	26.0
28.0				13.5/26.7m	13.5	13.5	13.5	13.5	13.5	13.5	28.0
30.0					13.5/29.3m	13.5	13.5	13.5	13.5	13.5	30.0
32.0						13.5/32.0m	13.5	13.5	13.5	13.5	32.0
34.0							13.5	13.5	13.5	13.5	34.0
36.0							13.5/34.6m	13.5	13.5	13.5	36.0
38.0								13.1/37.2m	12.7	12.5	38.0
40.0									11.7/39.9m	11.5	40.0
42.0										10.5	42.0
44.0										10.3/42.5m	44.0

※表中の太線で囲まれた部分は、ブーム等の強度によって定められた値です。
 ※75.1tウエイトでの能力設定はオプションです。

(単位:t)

ブーム長さ 作業半径 (m)	48.8	51.8	54.9	57.9	61.0	64.0	67.1	70.1	73.2	ブーム長さ 作業半径 (m)
10.0	13.5/11.0m									10.0
12.0	13.5	13.5/11.5m	13.5/12.1m	13.5/12.6m	13.5/13.1m	13.5/13.7m				12.0
14.0	13.5	13.5	13.5	13.5	13.5	13.5	13.5/14.2m	13.5/14.7m	13.5/15.3m	14.0
16.0	13.5	13.5	13.5	13.5	13.5	13.5	13.5	13.5	13.5	16.0
18.0	13.5	13.5	13.5	13.5	13.5	13.5	13.5	13.5	13.5	18.0
20.0	13.5	13.5	13.5	13.5	13.5	13.5	13.5	13.5	13.5	20.0
22.0	13.5	13.5	13.5	13.5	13.5	13.5	13.5	13.5	13.5	22.0
24.0	13.5	13.5	13.5	13.5	13.5	13.5	13.5	13.5	13.5	24.0
26.0	13.5	13.5	13.5	13.5	13.5	13.5	13.5	13.5	13.5	26.0
28.0	13.5	13.5	13.5	13.5	13.5	13.5	13.5	13.5	13.5	28.0
30.0	13.5	13.5	13.5	13.5	13.5	13.5	13.5	13.5	13.5	30.0
32.0	13.5	13.5	13.5	13.5	13.5	13.5	13.5	13.5	13.5	32.0
34.0	13.5	13.5	13.5	13.5	13.5	13.5	13.2	13.0	12.9	34.0
36.0	13.3	13.0	12.8	12.6	12.3	12.2	11.9	11.7	11.6	36.0
38.0	12.2	11.9	11.6	11.4	11.2	11.0	10.7	10.5	10.4	38.0
40.0	11.2	10.9	10.6	10.4	10.2	10.0	9.7	9.5	9.4	40.0
42.0	10.3	10.0	9.8	9.5	9.3	9.1	8.8	8.6	8.5	42.0
44.0	9.4	9.2	9.0	8.7	8.5	8.3	8.0	7.7	7.6	44.0
46.0	8.9/45.1m	8.5	8.2	8.0	7.7	7.6	7.3	7.0	6.8	46.0
48.0		7.9/47.8m	7.6	7.3	7.1	6.9	6.5	6.2	6.0	48.0
50.0			7.0	6.7	6.5	6.2	5.8	5.4	5.3	50.0
52.0			6.9/50.4m	6.1	5.8	5.6	5.1	4.8	4.6	52.0
54.0				5.8/53.1m	5.2	5.0	4.5	4.2	4.0	54.0
56.0					4.7/55.7m	4.4	4.0	3.6	3.4	56.0
58.0						3.8	3.5	3.1	2.9	58.0
60.0						3.7/58.3m	3.0	2.6/60.0m	2.4/60.0m	60.0
62.0							2.8/61.0m			62.0

※表中の太線で囲まれた部分は、ブーム等の強度によって定められた値です。
 ※75.1tウエイトでの能力設定はオプションです。

▶ ロング主ブーム定格総荷重表(75.1tウエイト)

▲7200のみ

(単位:t)

ブーム長さ 作業半径(m)	73.2	76.2	79.2	82.3	85.3	88.4	91.4	ブーム長さ 作業半径(m)
14.0	37.5/14.4m	34.5/14.9m	32.6/15.4m					14.0
16.0	36.0	33.5	32.1	31.2/16.0m	25.0/16.5m	25.0/17.0m	21.5/17.6m	16.0
18.0	34.4	31.9	30.6	29.6	25.0	25.0	21.2	18.0
20.0	32.9	30.4	29.1	28.2	25.0	24.1	20.0	20.0
22.0	29.2	29.1	27.9	26.9	25.0	23.0	18.9	22.0
24.0	25.8	25.7	25.6	25.5	25.0	22.0	17.8	24.0
26.0	23.0	22.9	22.8	22.7	22.7	21.1	16.9	26.0
28.0	20.6	20.5	20.4	20.4	20.4	20.3	16.0	28.0
30.0	18.6	18.5	18.4	18.4	18.4	18.3	15.3	30.0
32.0	16.9	16.8	16.7	16.7	16.6	16.6	14.5	32.0
34.0	15.4	15.3	15.2	15.2	15.1	15.1	13.8	34.0
36.0	14.1	14.0	13.9	13.9	13.8	13.8	13.1	36.0
38.0	13.0	12.9	12.7	12.7	12.7	12.6	12.5	38.0
40.0	12.0	11.8	11.7	11.7	11.6	11.6	11.6	40.0
42.0	11.0	10.9	10.8	10.8	10.7	10.7	10.6	42.0
44.0	10.2	10.1	10.0	9.9	9.9	9.8	9.8	44.0
46.0	9.5	9.3	9.2	9.2	9.1	9.1	9.0	46.0
48.0	8.8	8.7	8.5	8.5	8.4	8.4	8.3	48.0
50.0	8.2	8.0	7.9	7.9	7.8	7.8	7.7	50.0
52.0	7.6	7.5	7.3	7.3	7.2	7.2	7.1	52.0
54.0	7.1	6.9	6.8	6.8	6.7	6.6	6.6	54.0
56.0	6.6	6.5	6.3	6.3	6.2	6.2	6.1	56.0
58.0	6.2	6.0	5.9	5.8	5.7	5.7	5.6	58.0
60.0	5.8	5.6	5.4	5.4	5.2	5.2	5.1	60.0
62.0	5.4	5.2	5.0	4.9	4.8	4.7	4.6	62.0
64.0	5.0	4.8	4.6	4.5	4.4	4.3	4.2	64.0
66.0	4.8/64.9m	4.4	4.2	4.1	4.0	3.9	3.8	66.0
68.0		4.1/67.5m	3.8	3.7	3.6	3.5	3.4	68.0
70.0			3.5	3.4	3.2	3.2	3.1	70.0
72.0			3.5/70.2m	3.1	2.9	2.8	2.7	72.0
74.0				3.0/72.8m	2.6	2.5/74.0m	2.4/74.0m	74.0
76.0					2.4/74.5m			76.0

※表中の太線で囲まれた部分は、ブーム等の強度によって定められた値です。
 ※75.1tウエイトでの能力設定はオプションです。

▶ ロング補助シーブ定格総荷重表(75.1tウエイト、主ブームにフックなし)

▲7200のみ

(単位:t)

ブーム長さ 作業半径(m)	73.2	76.2	79.2	82.3	85.3	88.4	ブーム長さ 作業半径(m)
14.0	13.5/15.1m	13.5/15.7m					14.0
16.0	13.5	13.5	13.5/16.2m	13.5/16.7m	13.5/17.3m	13.5/17.8m	16.0
18.0	13.5	13.5	13.5	13.5	13.5	13.5	18.0
20.0	13.5	13.5	13.5	13.5	13.5	13.5	20.0
22.0	13.5	13.5	13.5	13.5	13.5	13.5	22.0
24.0	13.5	13.5	13.5	13.5	13.5	13.5	24.0
26.0	13.5	13.5	13.5	13.5	13.5	13.5	26.0
28.0	13.5	13.5	13.5	13.5	13.5	13.5	28.0
30.0	13.5	13.5	13.5	13.5	13.5	13.5	30.0
32.0	13.5	13.5	13.5	13.5	13.5	13.5	32.0
34.0	13.5	13.5	13.5	13.5	13.5	13.5	34.0
36.0	13.5	13.5	13.5	13.5	13.5	13.5	36.0
38.0	12.7	12.6	12.4	12.4	12.4	12.3	38.0
40.0	11.7	11.5	11.4	11.4	11.3	11.3	40.0
42.0	10.7	10.6	10.5	10.5	10.4	10.4	42.0
44.0	9.9	9.8	9.7	9.6	9.6	9.5	44.0
46.0	9.2	9.0	8.9	8.9	8.8	8.8	46.0
48.0	8.5	8.4	8.2	8.2	8.1	8.1	48.0
50.0	7.9	7.7	7.6	7.6	7.5	7.5	50.0
52.0	7.3	7.2	7.0	7.0	6.9	6.9	52.0
54.0	6.8	6.6	6.5	6.5	6.4	6.3	54.0
56.0	6.3	6.2	6.0	6.0	5.9	5.9	56.0
58.0	5.9	5.7	5.6	5.5	5.4	5.4	58.0
60.0	5.5	5.3	5.1	5.1	4.9	4.9	60.0
62.0	5.1	4.9	4.7	4.6	4.5	4.4	62.0
64.0	4.7	4.5	4.3	4.2	4.1	4.0	64.0
66.0	4.3/66.0m	4.1	3.9	3.8	3.7	3.6	66.0
68.0		3.7	3.5	3.4	3.3	3.2	68.0
70.0		3.6/68.7m	3.2	3.1	2.9	2.9	70.0
72.0			3.0/71.3m	2.8	2.6/72.0m	2.5/72.0m	72.0
74.0				2.5/74.0m			74.0

※表中の太線で囲まれた部分は、ブーム等の強度によって定められた値です。
 ※75.1tウエイトでの能力設定はオプションです。

ラフティングタワー (117.1tウエイト)

▶全体図(単位: mm) ▲7200のみ

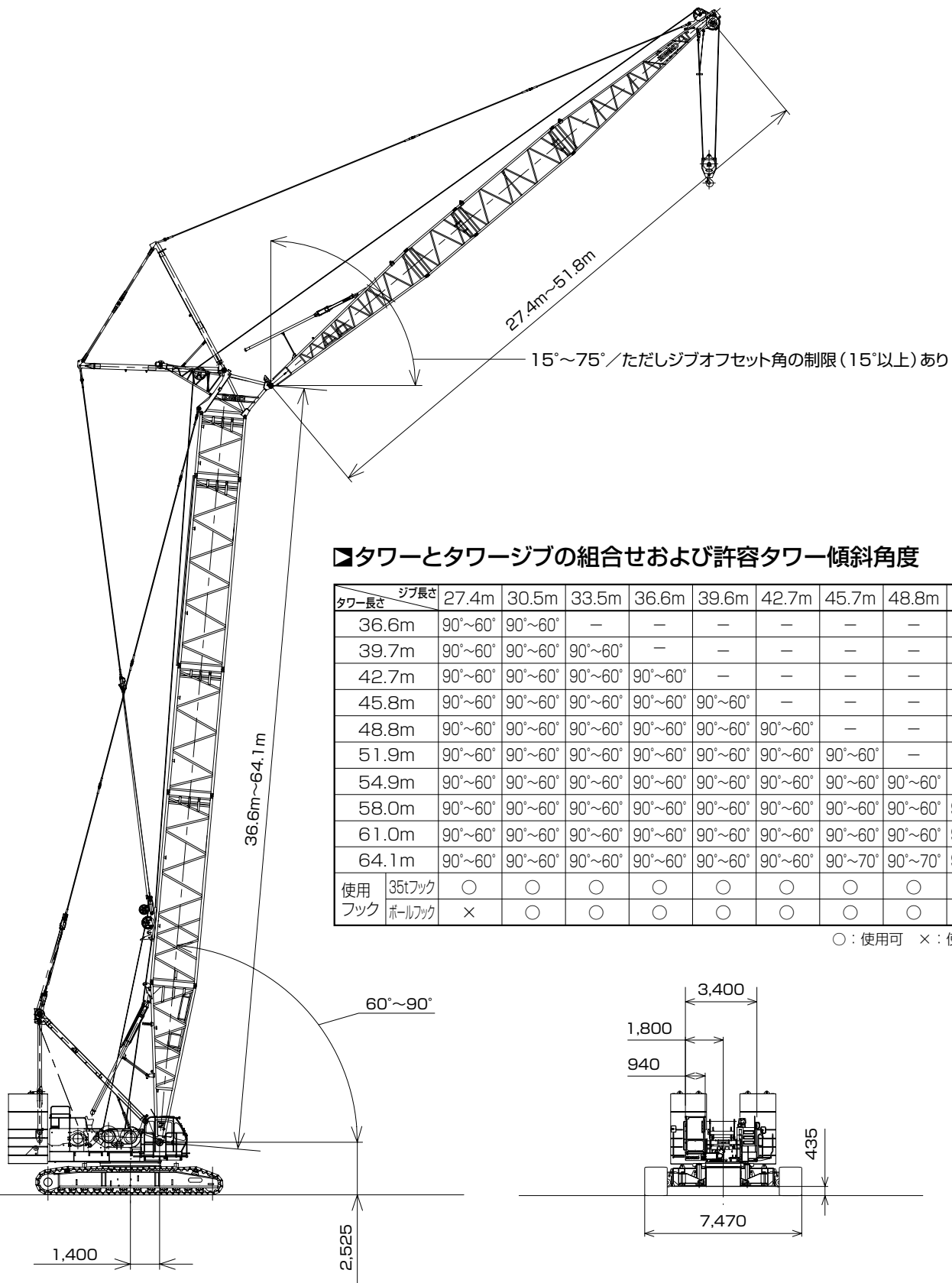

▶タワーとタワージブの組合せおよび許容タワー傾斜角度

タワー長さ \ ジブ長さ	27.4m	30.5m	33.5m	36.6m	39.6m	42.7m	45.7m	48.8m	51.8m	敷板
36.6m	90°~60°	90°~60°	—	—	—	—	—	—	—	—
39.7m	90°~60°	90°~60°	90°~60°	—	—	—	—	—	—	—
42.7m	90°~60°	90°~60°	90°~60°	90°~60°	—	—	—	—	—	—
45.8m	90°~60°	90°~60°	90°~60°	90°~60°	90°~60°	—	—	—	—	—
48.8m	90°~60°	90°~60°	90°~60°	90°~60°	90°~60°	90°~60°	—	—	—	—
51.9m	90°~60°	90°~60°	90°~60°	90°~60°	90°~60°	90°~60°	90°~60°	—	—	—
54.9m	90°~60°	90°~60°	90°~60°	90°~60°	90°~60°	90°~60°	90°~60°	90°~60°	—	—
58.0m	90°~60°	90°~60°	90°~60°	90°~60°	90°~60°	90°~60°	90°~60°	90°~60°	90°~70°	—
61.0m	90°~60°	90°~60°	90°~60°	90°~60°	90°~60°	90°~60°	90°~60°	90°~60°	90°~70°	—
64.1m	90°~60°	90°~60°	90°~60°	90°~60°	90°~60°	90°~60°	90°~70°	90°~70°	90°~70°	◎
使用フック	35tフック	○	○	○	○	○	○	○	○	⊗
ボールフック	×	○	○	○	○	○	○	○	○	

○: 使用可 ×: 使用不可 ◎: 必要

▶タワー構成 ▲7200のみ

- ※印は、これより短いタワーの組立可能な構成を示します。
- 9.1Aは、クローラークレーンの中間ブームとしても使用できます。
- 下部ブーム直近の9.1m中間ブームには、9.1Aを使用してください。
- 使用するガイラインの径はφ38mmです。

中間タワーの種類		
記号	タワー長さ	備考
3.0	3.0m	クレーンおよびタワー共用
6.1	6.1m	クレーンおよびタワー共用
9.1	9.1m	クレーンおよびタワー共用
9.1A	9.1m	タワー専用 (クレーンに兼用可能)

▶タワージブ構成 ▲7200のみ

- ※印は、これより短いタワージブの組立可能な構成を示します。
- 印は、ケーブルローラ取付位置を示します。
- 使用するガイラインの径はφ38mmです。

中間タワージブの種類		
記号	タワージブ長さ	備考
3.0A	3.0m	中継ジブ
3.0	3.0m	ロング中間ブーム共用
6.1	6.1m	ロング中間ブーム共用
9.1	9.1m	ロング中間ブーム共用

タワー長さ m (ft.)	タワー構成
36.6 (120)	
39.7 (130)	<p>※</p>
42.7 (140)	<p>※</p>
45.8 (150)	<p>※</p>
48.8 (160)	<p>※</p>
51.9 (170)	<p>※</p>
54.9 (180)	<p>※</p>
58.0 (190)	<p>※</p>
61.0 (200)	<p>※</p>
64.1 (210)	<p>※</p>

タワー長さ m (ft.)	タワージブ構成
27.4 (90)	
30.5 (100)	<p>※</p>
33.5 (110)	<p>※</p>
36.6 (120)	<p>※</p>
39.6 (130)	<p>※</p>
42.7 (140)	<p>※</p>
45.7 (150)	<p>※</p>
48.8 (160)	<p>※</p>
51.8 (170)	<p>※</p>

▶ 定格総荷重 ▲ 7200のみ

- 定格総荷重とは、水平堅土上における転倒荷重の78%以内で、フックブロック、玉掛用ワイヤロープ等のつり具の質量を含んだ値です。
- 作業半径とはクレーン旋回中心よりつり上荷重の重心までの水平距離を意味します。
- 実際につり上げ得る荷重は定格総荷重から（主フック+玉掛用ワイヤロープ等のつり具）の質量を差し引いた値になります。
- 定格総荷重をつる場合にも風の影響、地盤の状態、作業速度その他安全作業に有害な状況がある時はオペレータは荷重の軽減、作業速度を遅くするなど状況に応じた判断をする責任があります。
- 表中の空欄の個所では作業を行うことができません。
- クレーン作業中はガントリを最高位置に立ててください。

- すべてのタワー（ジブ）長さにおける中間タワーブーム（ジブ）の構成は取扱説明書の指示を厳守してください。
- ジブ長さ27.4mにて13.5tボールフックの使用はできません。
- 64.1mタワーの自立、降下の際には、クローラの前端に敷板（ブロック）を敷いて下さい。

△ 操作ミスなどによるつり荷の落下を防ぐため、クレーン作業では自由降下（フリーフォール）作業は行わないでください。

- 巻上げロープ巻掛本数に対する最大巻上荷重とフックの質量

フック呼称		35t	13.5tボールフック
最大巻上荷重 (t)	1本掛	13.5	13.5
	2本掛	25.0	—
フック質量		0.90t	0.45t

※ジブ長さ27.4mでの13.5tボールフックの使用はできません。

- 75.1tウエイトもオプション設定していますが、最長タワー長さは58.0mとなります。

▶ フック巻上限界 (単位:m) ▲ 7200のみ

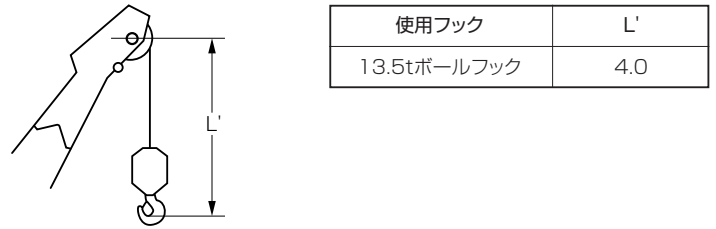
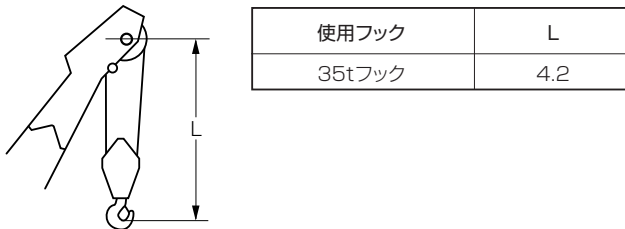

▶ タワー長さ 36.6m (117.1tウエイト) ▲ 7200のみ

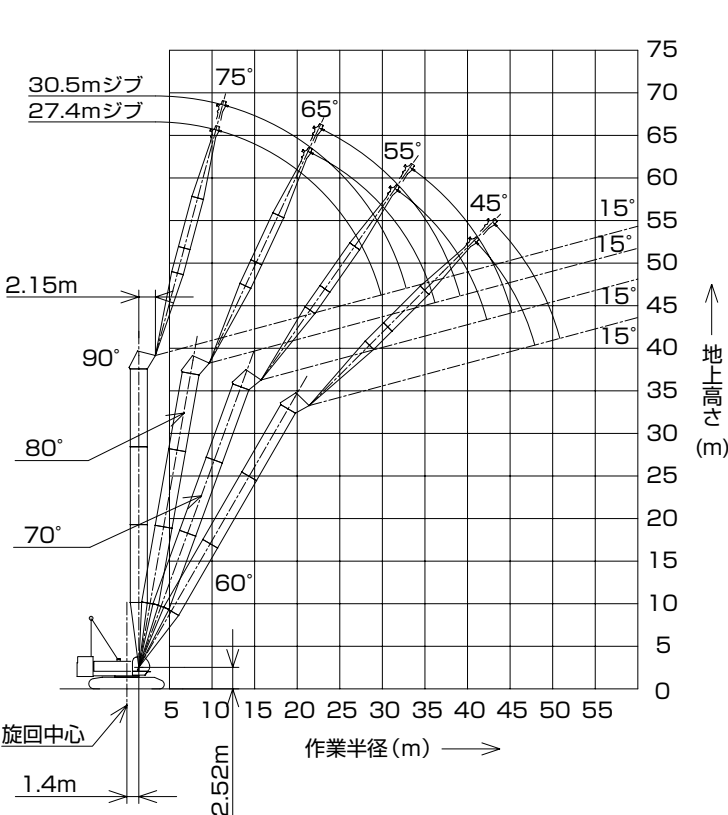

		(単位:t)							
タワー長さm	36.6								タワー長さm
ジブ長さm	27.4				30.5				ジブ長さm
タワー角度	90°	80°	70°	60°	90°	80°	70°	60°	タワー角度
作業半径 (m)	10.0	25.0/10.9m			25/11.7m				10.0
	12.0	25.0			25.0				12.0
	14.0	25.0			25.0				14.0
	16.0	25.0			25.0				16.0
	18.0	25.0			24.2				18.0
	20.0	24.2	23.4/21.7m		23.5				20.0
	22.0	23.2	23.2		22.7	21.9/23.0m			22.0
	24.0	21.0	21.0		21.0	21.0			24.0
	26.0	18.6	18.6		18.6	18.6			26.0
	28.0	16.0	16.8		16.7	16.7			28.0
	30.0	11.2/29.9m	15.2	14.1/31.9m	15.1	15.1			30.0
	32.0		14.0	14.0	12.0	13.9	13.0/33.7m		32.0
	34.0		12.8	12.8	10.6/32.8m	12.7	12.7		34.0
	36.0		11.8	11.8		11.7	11.7		36.0
	38.0		11.8/36.2m	11.1		11.0	11.0		38.0
	40.0			10.4	10.0/41.2m	10.6/39.2m	10.3		40.0
42.0			9.7	9.7		9.6	9.2/43.3m	42.0	
44.0			9.6/42.3m	9.1		9.0	9.0	44.0	
46.0				8.6		8.7/45.2m	8.5	46.0	
48.0				8.2			8.1	48.0	
50.0				8.2/47.9m			7.7	50.0	
52.0							7.6/50.8m	52.0	

※表中の太線で囲まれた部分は、ブーム等の強度によって定められた値です。

▶タワー長さ **39.7m** (117.1tウエイト) ▲7200のみ

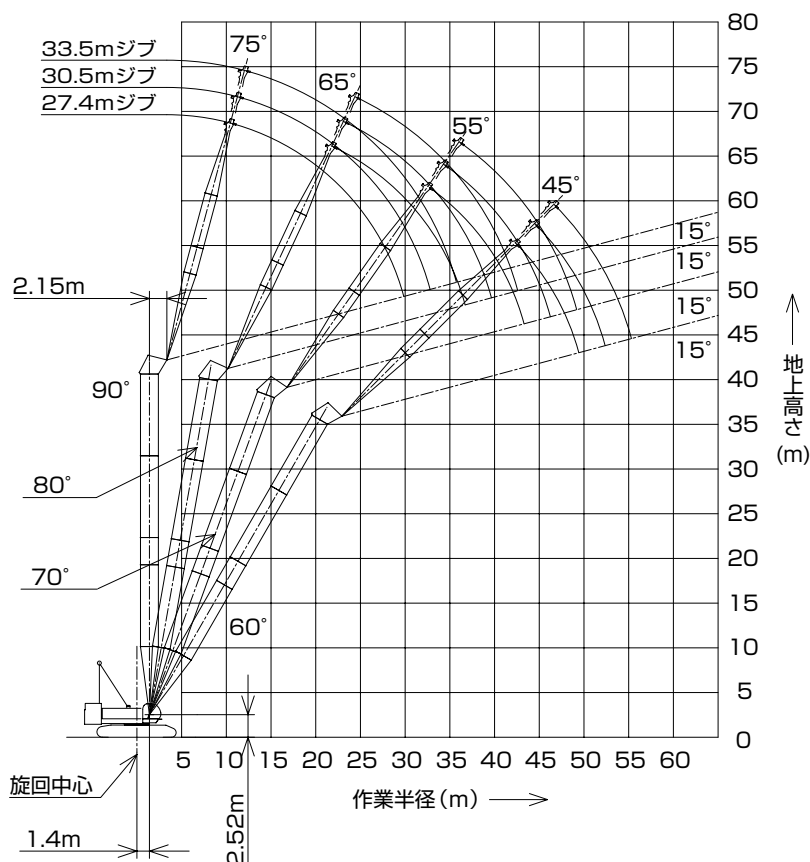

(単位:t)

タワー長さm	39.7												タワー長さm	
ジブ長さm	27.4				30.5				33.5				ジブ長さm	
タワー角度	90°	80°	70°	60°	90°	80°	70°	60°	90°	80°	70°	60°	タワー角度	
作業半径 (m)	10.0	25.0/10.9m			25.0/11.7m								10.0	
	12.0	25.0			25.0				25.0/12.5m				12.0	
	14.0	25.0			25.0				25.0				14.0	
	16.0	25.0			25.0				24.2				16.0	
	18.0	25.0			24.2				23.4				18.0	
	20.0	24.2			23.5				22.6				20.0	
	22.0	23.2	22.8/22.3m		22.7	21.4/23.6m			21.8				22.0	
	24.0	20.9	20.9		21.0	20.9			21.0	20.2/24.8m			24.0	
	26.0	18.5	18.6		18.6	18.6			18.8	18.6			26.0	
	28.0	16.1	16.8		16.7	16.7			16.7	16.7			28.0	
	30.0	11.2/29.9m	15.2		15.1	15.1			15.3	15.1			30.0	
	32.0		14.0	13.4/33.0m		12.0	13.9			14.0	13.9		32.0	
	34.0		12.8	12.8		10.6/32.8m	12.7	12.4/34.7m		12.0	12.7		34.0	
	36.0		11.8	11.8			11.7	11.7		9.2/35.8m	11.7	11.5/36.5m	36.0	
	38.0		11.5/36.7m	11.1			11.0	11.0			11.0	11.0	38.0	
	40.0			10.4			10.4/39.7m	10.3			10.2	10.3	40.0	
	42.0				9.7	9.5/42.7m		9.6			9.6	9.6	42.0	
	44.0			9.3/43.3m	9.1			9.0	8.7/44.9m		9.4/42.6m	9.0	44.0	
	46.0				8.6			8.5	8.5			8.4	8.2/47.0m	46.0
	48.0				8.2			8.4/46.3m	8.1			8.0	8.0	48.0
50.0				8.0/49.4m				7.7			7.7/49.2m	7.6	50.0	
52.0								7.3				7.2	52.0	
54.0								7.2/52.4m				6.8	54.0	
56.0												6.6/55.3m	56.0	

※表中の太線で囲まれた部分は、ブーム等の強度によって定められた値です。

▶タワー長さ **42.7m** (117.1tウエイト) ▲7200のみ

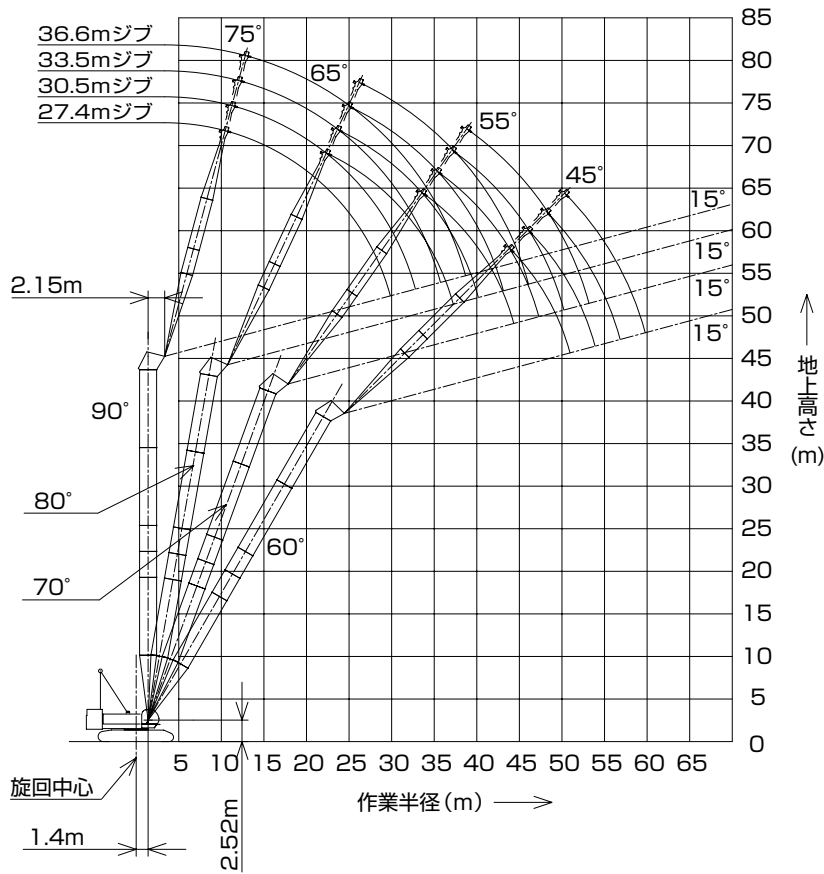

(単位:t)

タワー長さm	42.7																タワー長さm
ジブ長さm	27.4				30.5				33.5				36.6				ジブ長さm
タワー角度	90°	80°	70°	60°	90°	80°	70°	60°	90°	80°	70°	60°	90°	80°	70°	60°	タワー角度
作業半径(m)	10.0	25.0/10.9m			25.0/11.7m												10.0
	12.0	25.0			25.0				25.0/12.5m				23.9/13.3m				12.0
	14.0	25.0			25.0				25.0				23.6				14.0
	16.0	25.0			25.0				24.2				22.9				16.0
	18.0	25.0			24.2				23.4				22.2				18.0
	20.0	24.2			23.5				22.6				21.4				20.0
	22.0	23.2	22.3/22.8m		22.7				21.8				20.7				22.0
	24.0	20.9	20.9		21.0	20.9/24.1m			21.0	19.6/25.4m			19.9				24.0
	26.0	18.5	18.6		18.6	18.6			18.8	18.6			18.8	18.2/26.7m			26.0
	28.0	16.3	16.8		16.7	16.7			16.7	16.7			16.8	16.7			28.0
	30.0	11.3/29.9m	15.2		15.1	15.1			15.3	15.1			15.2	15.0			30.0
	32.0		14.0		12.0	13.9			14.0	13.9			14.0	13.8			32.0
	34.0		12.8	12.8/34.0m	10.6/32.8m	12.7	11.8/35.8m		12.1	12.7			12.8	12.6			34.0
	36.0		11.8	11.8		11.7	11.7		9.2/35.8m	11.7			11.7	11.6			36.0
	38.0		11.4/37.3m	11.1		11.0	11.0			11.0	11.0/38.0m		9.3	10.9	10.4/39.3m		38.0
	40.0			10.4		10.3	10.3			10.2	10.3		8.7/38.7m	10.1	10.1		40.0
	42.0			9.7		10.2/40.2m	9.6			9.6	9.6			9.5	9.5		42.0
	44.0			9.1	9.0/44.2m		9.0			9.3/43.2m	9.0			8.9	8.9		44.0
	46.0			8.9/44.4m	8.6		8.5	8.4/46.4m			8.4			8.4	8.3		46.0
	48.0				8.2		8.2/47.3m	8.1			7.9	7.9/48.5m		8.3/46.1m	7.8		48.0
50.0				7.8			7.7			7.5	7.6			7.4	7.3/50.7m	50.0	
52.0				7.6/51.0m			7.3			7.5/50.2m	7.2			7.0	7.1	52.0	
54.0							6.9/53.9m				6.8			6.7/53.2m	6.7	54.0	
56.0											6.4				6.3	56.0	
58.0											6.3/56.8m				6.0	58.0	
60.0															5.7/59.8m	60.0	

※表中の太線で囲まれた部分は、ブーム等の強度によって定められた値です。

▶タワー長さ **45.8m** (117.1tウエイト) ▲7200のみ

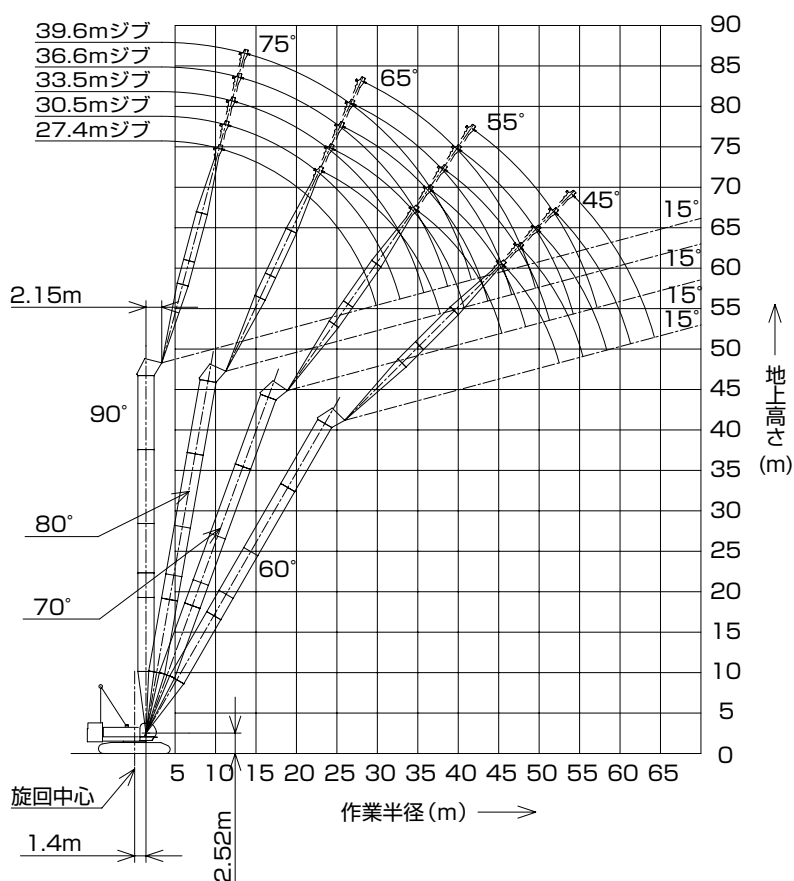

(単位:t)

タワー長さm	45.8																タワー長さm				
ジブ長さm	27.4				30.5				33.5				36.6				39.6				ジブ長さm
タワー角度	90°	80°	70°	60°	90°	80°	70°	60°	90°	80°	70°	60°	90°	80°	70°	60°	90°	80°	70°	60°	タワー角度
10.0	25.0/10.9m				25.0/11.7m																10.0
12.0	25.0				25.0				25.0/12.5m				23.9/13.3m								12.0
14.0	25.0				25.0				25.0				23.6						22.0/14.1m		14.0
16.0	25.0				25.0				24.2				22.9						21.4		16.0
18.0	25.0				24.2				23.4				22.2						20.8		18.0
20.0	24.2				23.5				22.6				21.4						20.2		20.0
22.0	23.2	21.7/23.3m			22.7				21.8				20.7						19.6		22.0
24.0	20.9	20.9			21.0	20.3/24.5m			21.0	18.7/25.9m			19.9					19.0			24.0
26.0	18.5	18.6			18.6	18.6			18.8	18.6			18.8	17.6/27.2m				18.3			26.0
28.0	16.3	16.8			16.7	16.7			16.7	16.7			16.8	16.7				16.8	16.3/28.5m		28.0
30.0	11.3/29.9m	15.2			15.1	15.1			15.3	15.1			15.2	15.0				15.2	14.9		30.0
32.0		14.0			12.0	13.9			14.0	13.9			14.0	13.8				14.0	13.7		32.0
34.0		12.8	12.3/35.0m		10.6/32.8m	12.7			12.1	12.7			12.8	12.6				12.8	12.5		34.0
36.0		11.8	11.8		11.7	11.5/36.6m			9.2/35.8m	11.7			11.6	11.6				11.8	11.5		36.0
38.0		11.2/37.8m	11.1		11.0	11.0			11.0	10.9/38.5m			9.3	10.9				10.8	10.8		38.0
40.0		10.4			10.3	10.3			10.2	10.3			8.7/38.7m	10.1	10.1/40.3m			9.3	10.0		40.0
42.0		9.7			10.1/40.7m	9.6			9.6	9.6				9.5	9.5			7.7/41.7m	9.4	9.4/42.0m	42.0
44.0		9.1	8.6/45.8m		9.0				9.1/43.7m	9.0			8.9	8.9				8.8	8.7		44.0
46.0		8.8/45.4m	8.6		8.5	8.1/47.9m			8.4				8.4	8.3				8.2	8.1		46.0
48.0		8.2			8.1	8.1			7.9				8.2/46.6m	7.8				7.6	7.6		48.0
50.0		7.8			7.7	7.7			7.5	7.6/50.1m			7.4					7.4	7.2		50.0
52.0		7.4			7.3				7.3/51.3m	7.2			7.0		7.0/52.2m			6.8			52.0
54.0			7.3/52.5m		6.9				6.8				6.6	6.7				6.4	6.3/54.4m		54.0
56.0					6.7/55.4m				6.4				6.6/54.2m	6.3				6.1	6.1		56.0
58.0									6.1				6.0					5.9/57.2m	5.8		58.0
60.0									6.0/58.4m				5.7					5.3			60.0
62.0													5.5/61.3m					5.3			62.0
64.0																		5.1			64.0
66.0																		5.0/64.3m			66.0

*表中の太線で囲まれた部分は、ブーム等の強度によって定められた値です。

▶タワー長さ **48.8m** (117.1tウエイト) ▲7200のみ

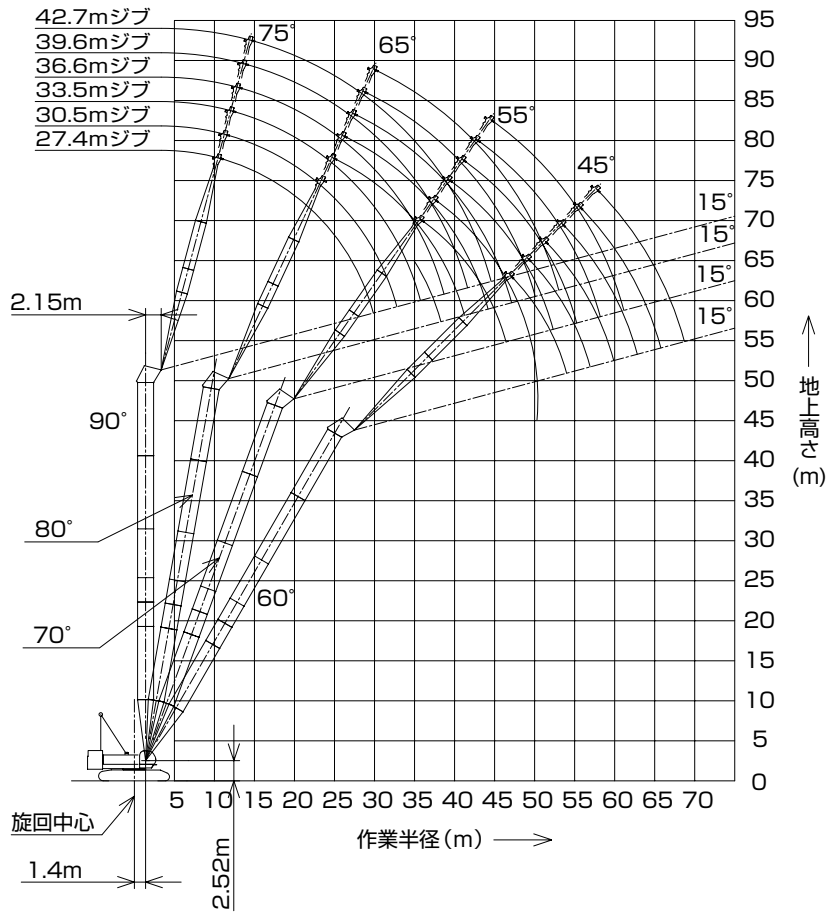

(単位:t)

タワー長さm	48.8								タワー長さm
ジブ長さm	27.4				30.5				ジブ長さm
タワー角度	90°	80°	70°	60°	90°	80°	70°	60°	タワー角度
作業半径(m)	10.0	25.0/10.9m				25.0/11.7m			10.0
	12.0	25.0				25.0			12.0
	14.0	25.0				25.0			14.0
	16.0	25.0				25.0			16.0
	18.0	25.0				24.2			18.0
	20.0	24.2				23.5			20.0
	22.0	23.2	21.2/23.9m			22.7			22.0
	24.0	20.9	20.9			21.0	19.7/25.1m		24.0
	26.0	18.5	18.6			18.6	18.6		26.0
	28.0	16.3	16.8			16.7	16.7		28.0
	30.0	11.3/29.9m	15.2			15.1	15.1		30.0
	32.0		14.0			12.0	13.9		32.0
	34.0		12.8			10.6/32.8m	12.7		34.0
	36.0		11.8	11.8/36.1m			11.7	11.1/37.8m	36.0
	38.0		11.1	11.1			11.0	11.0	38.0
	40.0		11.0/38.3m	10.4			10.3	10.3	40.0
	42.0			9.7			9.9/41.3m	9.6	42.0
	44.0			9.1				9.0	44.0
46.0			8.6	8.3/47.3m			8.5	46.0	
48.0			8.5/46.4m	8.2			8.0	7.8/49.4m	48.0
50.0				7.8			7.7/49.4m	7.7	50.0
52.0				7.4				7.3	52.0
54.0				7.0/54.0m				6.9	54.0
56.0								6.5	56.0
58.0								6.4/56.9m	58.0

*表中の太線で囲まれた部分は、ブーム等の強度によって定められた値です。

(単位:t)

タワー長さm	48.8								タワー長さm
ジブ長さm	33.5				36.6				ジブ長さm
タワー角度	90°	80°	70°	60°	90°	80°	70°	60°	タワー角度
作業半径(m)	12.0	25.0/12.5m			23.9/13.3m				12.0
	14.0	25.0			23.6				14.0
	16.0	24.2			22.9				16.0
	18.0	23.4			22.2				18.0
	20.0	22.6			21.4				20.0
	22.0	21.8			20.7				22.0
	24.0	21.0			19.9				24.0
	26.0	18.8	18.4/26.4m		18.8	17.0/27.7m			26.0
	28.0	16.7	16.7		16.8	16.7			28.0
	30.0	15.3	15.1		15.2	15.0			30.0
	32.0	14.0	13.9		14.0	13.8			32.0
	34.0	12.1	12.7		12.8	12.6			34.0
	36.0	9.2/35.8m	11.7		11.6	11.6			36.0
	38.0		11.0	10.3/39.6m	9.3	10.9			38.0
	40.0		10.2	10.2	8.7/38.7m	10.1	9.6/41.3m		40.0
	42.0		9.6	9.5		9.5	9.4		42.0
	44.0		8.9	8.9		8.9	8.8		44.0
	46.0		8.9/44.2m	8.4		8.4	8.3		46.0
	48.0			7.9		8.1/47.2m	7.8		48.0
	50.0			7.5	7.3/51.6m		7.4		50.0
52.0			7.1	7.2		7.0	6.8/53.7m	52.0	
54.0			7.1/52.3m	6.8		6.6	6.7	54.0	
56.0				6.4		6.4/55.3m	6.3	56.0	
58.0				6.1			6.0	58.0	
60.0				5.8/59.9m			5.7	60.0	
62.0							5.4	62.0	
64.0							5.3/62.8m	64.0	

※表中の太線で囲まれた部分は、ブーム等の強度によって定められた値です。

(単位:t)

タワー長さm	48.8								タワー長さm
ジブ長さm	39.6				42.7				ジブ長さm
タワー角度	90°	80°	70°	60°	90°	80°	70°	60°	タワー角度
作業半径(m)	14.0	22.0/14.1m			20.0/14.9m				14.0
	16.0	21.4			19.7				16.0
	18.0	20.8			19.2				18.0
	20.0	20.2			18.6				20.0
	22.0	19.6			18.1				22.0
	24.0	19.0			17.5				24.0
	26.0	18.3			17.0				26.0
	28.0	16.8	15.8/29.0m		16.5				28.0
	30.0	15.2	14.9		15.2	14.7/30.3m			30.0
	32.0	14.0	13.7		14.0	13.6			32.0
	34.0	12.8	12.5		12.8	12.4			34.0
	36.0	11.8	11.5		11.8	11.4			36.0
	38.0	10.8	10.8		10.9	10.6			38.0
	40.0	9.3	10.0		9.8	9.8			40.0
	42.0	7.7/41.7m	9.4	9.0/43.1m	8.9	9.2			42.0
	44.0		8.8	8.7	7.2	8.6	8.3/44.8m		44.0
	46.0		8.2	8.1	6.8/44.6m	8.0	7.9		46.0
	48.0		7.6	7.6		7.4	7.4		48.0
	50.0		7.2	7.2		7.0	7.0		50.0
	52.0		7.1/50.1m	6.8		6.6	6.6		52.0
54.0			6.4	6.1/55.9m	6.4/53.0m	6.2		54.0	
56.0			6.1	6.1		5.9		56.0	
58.0			5.8	5.8		5.6	5.6/58.1m	58.0	
60.0			5.8/58.2m	5.5		5.4	5.4	60.0	
62.0				5.3		5.3/61.2m	5.2	62.0	
64.0				5.1			5.0	64.0	
66.0				4.9/65.8m			4.8	66.0	
68.0							4.6	68.0	
70.0							4.5/68.7m	70.0	

※表中の太線で囲まれた部分は、ブーム等の強度によって定められた値です。

▶タワー長さ **51.9m** (117.1tウエイト) ▲7200のみ

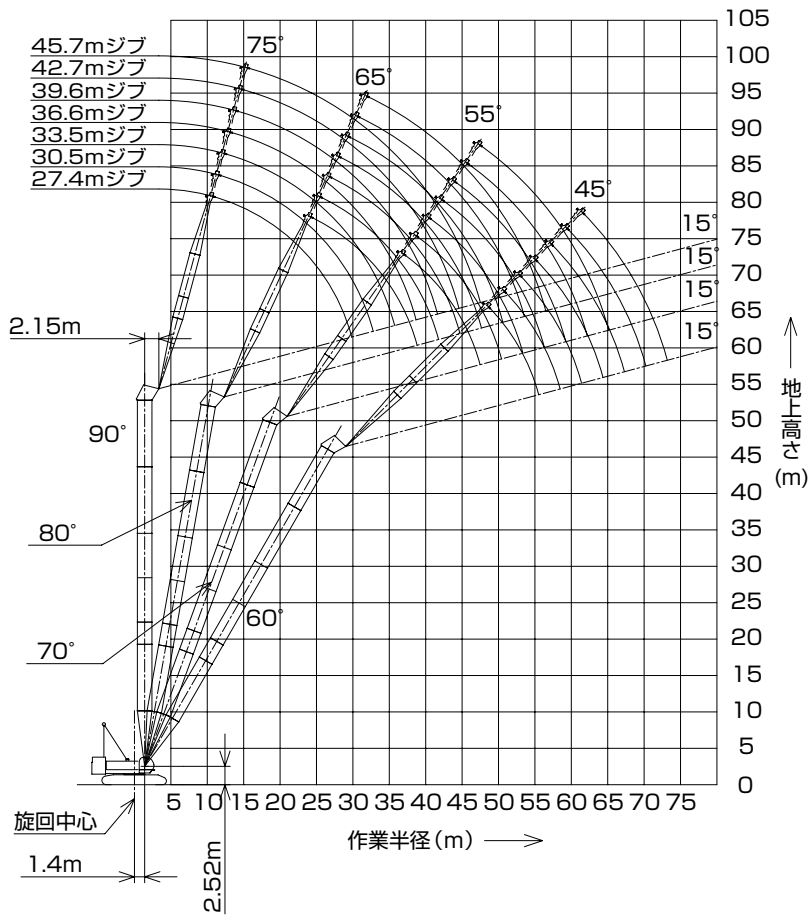

(単位:t)

タワー長さm	51.9												タワー長さm
ジブ長さm	27.4				30.5				33.5				ジブ長さm
タワー角度	90°	80°	70°	60°	90°	80°	70°	60°	90°	80°	70°	60°	タワー角度
作業半径 (m)	10.0	25.0/10.9m			25.0/11.7m								10.0
	12.0	25.0			25.0				25.0/12.5m				12.0
	14.0	25.0			25.0				25.0				14.0
	16.0	25.0			25.0				24.2				16.0
	18.0	25.0			24.2				23.4				18.0
	20.0	24.2			23.5				22.6				20.0
	22.0	23.2			22.7				21.8				22.0
	24.0	20.9	20.6/24.4m		21.0	19.0/25.7m			21.0				24.0
	26.0	18.5	18.6		18.6	18.6			18.8	17.8/27.0m			26.0
	28.0	16.3	16.8		16.7	16.7			16.7	16.7			28.0
	30.0	11.3/29.9m	15.2		15.1	15.1			15.3	15.1			30.0
	32.0		14.0		12.0	13.9			14.0	13.9			32.0
	34.0		12.8		10.6/32.8m	12.7			12.1	12.7			34.0
	36.0		11.8	11.4/37.1m		11.7			9.2/35.8m	11.7			36.0
	38.0		11.1	11.1		11.0	10.7/38.9m			11.0			38.0
	40.0		10.8/38.9m	10.4		10.3	10.3			10.2	10.0/40.6m		40.0
	42.0			9.7		9.7/41.8m	9.6			9.6	9.5		42.0
	44.0			9.1			9.0			8.9	8.9		44.0
	46.0			8.6			8.5			8.8/44.7m	8.4		46.0
	48.0			8.2/47.5m	8.0/48.8m		8.0				7.9		48.0
50.0				7.8		7.6	7.5/51.0m			7.5		50.0	
52.0				7.4		7.5/50.4m	7.3			7.1	7.0/53.1m	52.0	
54.0				7.0			6.9			6.9/53.4m	6.8	54.0	
56.0				6.7/55.5m			6.5				6.4	56.0	
58.0							6.2				6.1	58.0	
60.0							6.1/58.5m				5.8	60.0	
62.0											5.6/61.4m	62.0	

*表中の太線で囲まれた部分は、ブーム等の強度によって定められた値です。

(単位:t)

タワー長さm	51.9								タワー長さm
ジブ長さm	36.6				39.6				ジブ長さm
タワー角度	90°	80°	70°	60°	90°	80°	70°	60°	タワー角度
12.0	23.9/13.3m								12.0
14.0	23.6				22.0/14.1m				14.0
16.0	22.9				21.4				16.0
18.0	22.2				20.8				18.0
20.0	21.4				20.2				20.0
22.0	20.7				19.6				22.0
24.0	19.9				19.0				24.0
26.0	18.8				18.3				26.0
28.0	16.8	16.6/28.2m			16.8	15.4/29.5m			28.0
30.0	15.2	15.0			15.2	14.9			30.0
32.0	14.0	13.8			14.0	13.7			32.0
34.0	12.8	12.6			12.8	12.5			34.0
36.0	11.6	11.6			11.8	11.5			36.0
38.0	9.3	10.9			10.8	10.8			38.0
40.0	8.7/38.7m	10.1			9.3	10.0			40.0
42.0		9.5	9.3/42.4m		7.7/41.7m	9.4			42.0
44.0		8.9	8.8			8.8	8.7/44.1m		44.0
46.0		8.4	8.3			8.2	8.1		46.0
48.0		7.9/47.7m	7.8			7.6	7.6		48.0
50.0			7.4			7.2	7.2		50.0
52.0			7.0			7.1/50.6m	6.8		52.0
54.0			6.6	6.4/55.3m			6.4		54.0
56.0			6.3	6.3			6.1	5.9/57.4m	56.0
58.0			6.3/56.3m	6.0			5.8	5.8	58.0
60.0				5.7			5.6/59.3m	5.5	60.0
62.0				5.4				5.2	62.0
64.0				5.2				5.0	64.0
66.0				5.1/64.4m				4.8	66.0
68.0								4.6/67.3m	68.0

※表中の太線で囲まれた部分は、ブーム等の強度によって定められた値です。

(単位:t)

タワー長さm	51.9								タワー長さm
ジブ長さm	42.7				45.7				ジブ長さm
タワー角度	90°	80°	70°	60°	90°	80°	70°	60°	タワー角度
14.0	20.0/14.9m				17.4/15.7m				14.0
16.0	19.7				17.4				16.0
18.0	19.2				16.9				18.0
20.0	18.6				16.4				20.0
22.0	18.1				16.0				22.0
24.0	17.5				15.5				24.0
26.0	17.0				15.0				26.0
28.0	16.5				14.6				28.0
30.0	15.2	14.4/30.8m			14.1				30.0
32.0	14.0	13.6			13.6	13.4/32.1m			32.0
34.0	12.8	12.4			12.6	12.3			34.0
36.0	11.8	11.4			11.6	11.3			36.0
38.0	10.8	10.6			10.6	10.5			38.0
40.0	9.8	9.8			9.7	9.7			40.0
42.0	8.9	9.2			8.9	9.0			42.0
44.0	7.2	8.6	7.9/45.9m		8.1	8.4			44.0
46.0	6.8/44.6m	8.0	7.9		7.1	7.8	7.4/47.6m		46.0
48.0		7.4	7.4		6.1/47.5m	7.2	7.3		48.0
50.0		7.0	7.0			6.8	6.8		50.0
52.0		6.6	6.6			6.4	6.4		52.0
54.0		6.2/53.6m	6.2			6.0	6.0		54.0
56.0			5.9			5.7	5.7		56.0
58.0			5.6	5.3/59.6m		5.6/56.5m	5.4		58.0
60.0			5.4	5.3			5.2	4.8/61.7m	60.0
62.0			5.2	5.0			5.0	4.8	62.0
64.0			5.2/62.2m	4.8			4.8	4.6	64.0
66.0				4.6			4.6/65.2m	4.4	66.0
68.0				4.4				4.2	68.0
70.0				4.2				4.0	70.0
72.0				4.2/70.2m				3.8	72.0
74.0								3.7/73.2m	74.0

※表中の太線で囲まれた部分は、ブーム等の強度によって定められた値です。

▶タワー長さ **54.9m** (117.1tウエイト) ▲7200のみ

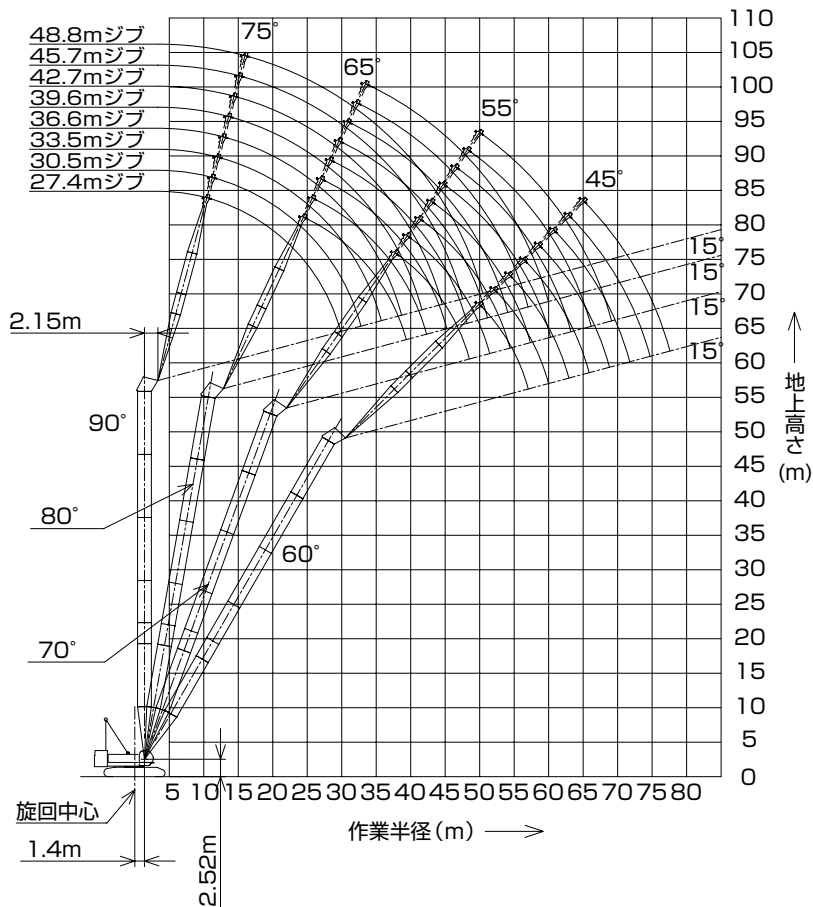

(単位:t)

タワー長さm	54.9												タワー長さm
ジブ長さm	27.4				30.5				33.5				ジブ長さm
タワー角度	90°	80°	70°	60°	90°	80°	70°	60°	90°	80°	70°	60°	タワー角度
作業半径 (m)	10.0	25.0/10.9m			25.0/11.7m								10.0
	12.0	25.0			25.0				25.0/12.5m				12.0
	14.0	25.0			25.0				25.0				14.0
	16.0	25.0			25.0				24.2				16.0
	18.0	25.0			24.2				23.4				18.0
	20.0	24.2			23.5				22.6				20.0
	22.0	23.2			22.7				21.7				22.0
	24.0	20.9	20.0/24.9m		21.0				21.0				24.0
	26.0	18.5	18.6		18.6	18.6/26.2m			18.8	17.2/27.5m			26.0
	28.0	16.3	16.8		16.7	16.7			16.7	16.7			28.0
	30.0	11.3/29.9m	15.2		15.1	15.1			15.3	15.1			30.0
	32.0		14.0		12.0	13.9			14.0	13.9			32.0
	34.0		12.8		10.6/32.8m	12.7			12.2	12.7			34.0
	36.0		11.8			11.7			9.3/35.8m	11.7			36.0
	38.0		11.1	11.0/38.2m			11.0	10.3/39.9m		11.0			38.0
	40.0		10.6/39.4m	10.4			10.3	10.3		10.2	9.6/41.7m		40.0
	42.0			9.7			9.5	9.6		9.6	9.5		42.0
	44.0			9.1			9.5/42.3m	9.0		8.9	8.9		44.0
	46.0			8.6				8.5		8.6/45.3m	8.4		46.0
	48.0			8.2				8.0			7.9		48.0
50.0			8.1/48.5m	7.7/50.3m			7.6			7.5		50.0	
52.0				7.4			7.3/51.5m	7.2/52.5m		7.1		52.0	
54.0				7.0				6.9		6.8	6.7/54.6m	54.0	
56.0				6.6				6.5		6.7/54.4m	6.4	56.0	
58.0				6.4/57.0m				6.1			6.0	58.0	
60.0								5.8/60.0m			5.7	60.0	
62.0											5.4	62.0	
64.0											5.3/62.9m	64.0	

※表中の太線で囲まれた部分は、ブーム等の強度によって定められた値です。

(単位:t)

タワー長さm		54.9												タワー長さm
ジブ長さm		36.6				39.6				42.7				ジブ長さm
タワー角度		90°	80°	70°	60°	90°	80°	70°	60°	90°	80°	70°	60°	タワー角度
作業半径(m)	12.0	23.9/13.3m												12.0
	14.0	23.6				22.0/14.1m				20.0/14.9m				14.0
	16.0	22.9				21.4				19.7				16.0
	18.0	22.2				20.8				19.2				18.0
	20.0	21.4				20.2				18.6				20.0
	22.0	20.7				19.6				18.1				22.0
	24.0	19.9				19.0				17.5				24.0
	26.0	18.8				18.3				17.0				26.0
	28.0	16.8	16.2/28.8m			16.8				16.5				28.0
	30.0	15.2	15.0			15.2	14.9/30.1m			15.2	14.1/31.4m			30.0
	32.0	14.0	13.8			14.0	13.7			14.0	13.6			32.0
	34.0	12.8	12.6			12.8	12.5			12.8	12.4			34.0
	36.0	11.6	11.6			11.8	11.5			11.8	11.4			36.0
	38.0	9.3	10.9			10.8	10.8			10.8	10.6			38.0
	40.0	8.7/38.7m	10.1			9.5	10.0			9.8	9.8			40.0
	42.0		9.5	9.0/43.4m		7.9/41.7m	9.4			8.8	9.2			42.0
	44.0		8.9	8.8			8.8	8.3/45.2m		7.3	8.6			44.0
	46.0		8.4	8.3			8.2	8.1		6.9/44.6m	8.0	7.7/46.9m		46.0
	48.0		7.8	7.8			7.6	7.6			7.4	7.4		48.0
	50.0		7.8/48.2m	7.4			7.2	7.2			7.0	7.0		50.0
	52.0			7.0			6.9/51.2m	6.8			6.6	6.6		52.0
	54.0			6.6				6.4			6.2	6.2		54.0
	56.0			6.3	6.1/56.8m			6.1			6.2/54.1m	5.9		56.0
	58.0			6.0/57.4m	5.9			5.8	5.7/58.9m			5.6		58.0
60.0				5.6			5.6	5.5			5.4	5.1/61.1m	60.0	
62.0				5.3			5.6/60.3m	5.3			5.2	5.0	62.0	
64.0				5.1				5.0			5.0/63.3m	4.8	64.0	
66.0				4.9/65.9m				4.8				4.6	66.0	
68.0								4.6				4.4	68.0	
70.0								4.5/68.8m				4.2	70.0	
72.0												4.0/71.8m	72.0	

※表中の太線で囲まれた部分は、ブーム等の強度によって定められた値です。

(単位:t)

タワー長さm		54.9												タワー長さm
ジブ長さm		45.7				48.8				48.8				ジブ長さm
タワー角度		90°	80°	70°	60°	90°	80°	70°	60°	90°	80°	70°	60°	タワー角度
作業半径(m)	14.0	17.4/15.7m												14.0
	16.0	17.4					15.4/16.5m							16.0
	18.0	16.9					15.0							18.0
	20.0	16.4					14.6							20.0
	22.0	16.0					14.2							22.0
	24.0	15.5					13.7							24.0
	26.0	15.0					13.3							26.0
	28.0	14.6					12.9							28.0
	30.0	14.1					12.5							30.0
	32.0	13.6	13.4/32.6m				12.0	12.1/33.9m						32.0
	34.0	12.6	12.3				11.6	12.1						34.0
	36.0	11.6	11.3				10.9	11.1						36.0
	38.0	10.6	10.5				10.1	10.2						38.0
	40.0	9.7	9.7				9.4	9.4						40.0
	42.0	8.8	9.0				8.6	8.7						42.0
	44.0	8.1	8.4				7.9	8.1						44.0
	46.0	7.1	7.8				7.3	7.6						46.0
	48.0	6.1/47.5m	7.2	7.1/48.7m			6.6	7.0						48.0
	50.0		6.8	6.8			5.6	6.6	6.5/50.4m					50.0
	52.0		6.4	6.4			5.3/50.5m	6.2	6.2					52.0
	54.0		6.0	6.0				5.8	5.8					54.0
	56.0		5.7	5.7				5.5	5.5					56.0
	58.0		5.5/57.0m	5.4				5.2	5.2					58.0
	60.0			5.2				5.0/60.0m	5.0					60.0
62.0			5.0	4.7/63.3m				4.8					62.0	
64.0			4.8	4.6				4.6	4.3/65.4m				64.0	
66.0			4.6	4.4				4.4	4.2				66.0	
68.0			4.6/66.2m	4.2				4.2	4.0				68.0	
70.0				4.0				4.1/69.1m	3.8				70.0	
72.0				3.8					3.6				72.0	
74.0				3.6					3.4				74.0	
76.0				3.5/74.7m					3.2				76.0	
78.0									3.0/77.7m				78.0	

※表中の太線で囲まれた部分は、ブーム等の強度によって定められた値です。

▶タワー長さ **58.0m** (117.1tウエイト) ▲7200のみ

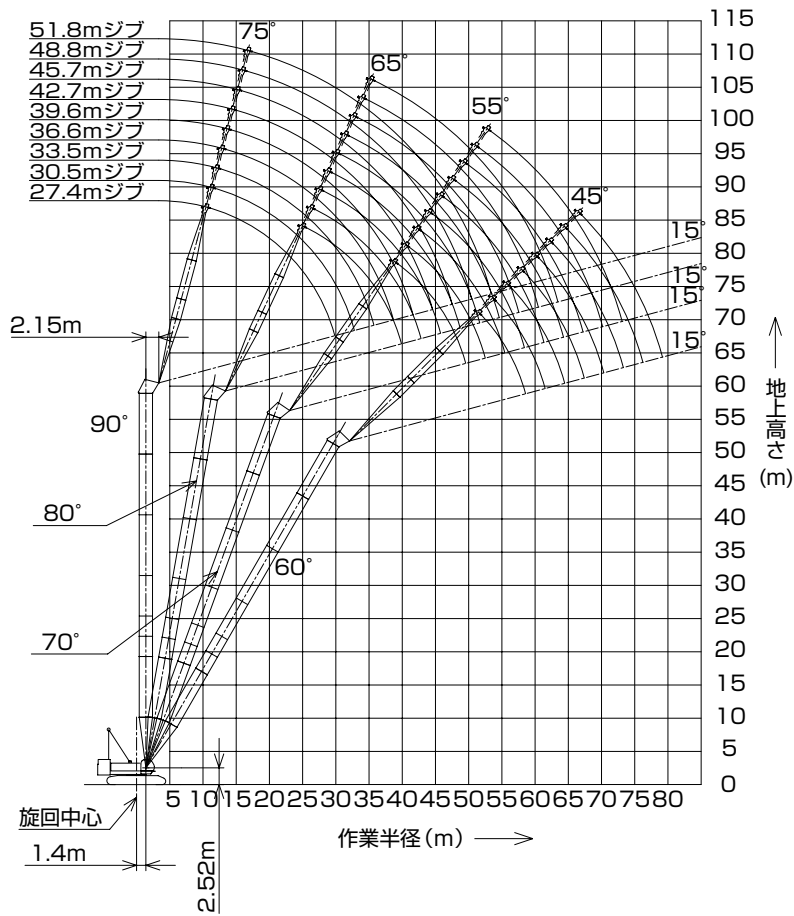

(単位:t)

タワー長さm	58.0												タワー長さm
ジブ長さm	27.4				30.5				33.5				ジブ長さm
タワー角度	90°	80°	70°	60°	90°	80°	70°	60°	90°	80°	70°	60°	タワー角度
作業半径(m)	10.0	25.0/10.9m			25.0/11.7m								10.0
	12.0	25.0			25.0				25.0/12.5m				12.0
	14.0	25.0			25.0				25.0				14.0
	16.0	25.0			25.0				24.2				16.0
	18.0	24.9			24.2				23.4				18.0
	20.0	24.0			23.5				22.6				20.0
	22.0	23.0			22.7				21.7				22.0
	24.0	20.7	19.4/25.4m		21.0				21.0				24.0
	26.0	18.3	18.6		18.6	18.1/26.7m			18.8				26.0
	28.0	16.3	16.8		16.7	16.7			16.7	16.7/28.0m			28.0
	30.0	11.3/29.9m	15.2		15.1	15.1			15.3	15.1			30.0
	32.0		14.0		12.0	13.9			14.0	13.9			32.0
	34.0		12.8		10.6/32.8m	12.7			12.2	12.7			34.0
	36.0		11.8			11.7			9.3/35.8m	11.7			36.0
	38.0		11.1	10.6/39.7m		11.0				11.0			38.0
	40.0		10.4/39.9m	10.4		10.3	10.0/41.0m			10.2			40.0
	42.0			9.7		9.5	9.6			9.6	9.2/42.7m		42.0
	44.0			9.1		9.3/42.9m	9.0			8.9	8.9		44.0
	46.0			8.6			8.5			8.5/45.8m	8.4		46.0
	48.0			8.2			8.0				7.9		48.0
50.0			7.9/49.6m	7.4/51.8m		7.6				7.5		50.0	
52.0				7.4		7.3				7.1		52.0	
54.0				7.0		7.2/52.5m	6.9/54.0m			6.8		54.0	
56.0				6.6			6.5			6.5/55.5m	6.4/56.2m	56.0	
58.0				6.2			6.1				6.0	58.0	
60.0				6.1/58.6m			5.8				5.7	60.0	
62.0							5.6/61.5m				5.4	62.0	
64.0											5.1	64.0	
66.0											5.0/64.5m	66.0	

※表中の太線で囲まれた部分は、ブーム等の強度によって定められた値です。

(単位:t)

タワー長さm	58.0												タワー長さm
ジブ長さm	36.6				39.6				42.7				ジブ長さm
タワー角度	90°	80°	70°	60°	90°	80°	70°	60°	90°	80°	70°	60°	タワー角度
12.0	23.9/13.3m												12.0
14.0	23.6				22.0/14.1m				20.0/14.9m				14.0
16.0	22.9				21.4				19.7				16.0
18.0	22.2				20.8				19.2				18.0
20.0	21.4				20.2				18.6				20.0
22.0	20.7				19.6				18.1				22.0
24.0	19.9				19.0				17.5				24.0
26.0	18.8				18.3				17.0				26.0
28.0	16.8	15.7/29.3m			16.8				16.5				28.0
30.0	15.2	15.0			15.2	14.8/30.6m			15.2	13.7/31.9m			30.0
32.0	14.0	13.8			14.0	13.7			14.0	13.6			32.0
34.0	12.8	12.6			12.8	12.5			12.8	12.4			34.0
36.0	11.6	11.6			11.8	11.5			11.8	11.4			36.0
38.0	9.5	10.9			10.7	10.8			10.8	10.6			38.0
40.0	8.9/38.7m	10.1			9.5	10.0			9.8	9.8			40.0
42.0		9.5			7.9/41.7m	9.4			8.8	9.2			42.0
44.0		8.9	8.7/44.5m			8.8			7.4	8.6			44.0
46.0		8.4	8.3			8.2	8.1/46.2m		7.0/44.6m	8.0			46.0
48.0		7.8	7.8			7.6	7.6			7.4	7.4/48.0m		48.0
50.0		7.7/48.7m	7.4			7.2	7.2			7.0	7.0		50.0
52.0			7.0			6.8/51.7m	6.8			6.6	6.6		52.0
54.0			6.6				6.4			6.2	6.2		54.0
56.0			6.3				6.1			6.1/54.6m	5.9		56.0
58.0			6.0	5.8/58.3m			5.8				5.6		58.0
60.0			5.9/58.4m	5.6			5.6	5.3/60.5m			5.4		60.0
62.0				5.3			5.4/61.3m	5.1		5.2	4.8/62.6m		62.0
64.0				5.0				4.8		4.9	4.6		64.0
66.0				4.8				4.6			4.8/64.3m	4.4	66.0
68.0				4.6/67.4m				4.4				4.2	68.0
70.0								4.2				4.0	70.0
72.0								4.2/70.3m				3.8	72.0
74.0												3.6/73.3m	74.0

※表中の太線で囲まれた部分は、ブーム等の強度によって定められた値です。

(単位:t)

タワー長さm	58.0												タワー長さm
ジブ長さm	45.7				48.8				51.8				ジブ長さm
タワー角度	90°	80°	70°	60°	90°	80°	70°	60°	90°	80°	70°	タワー角度	
14.0	17.4/15.7m												14.0
16.0	17.4				15.4/16.5m				13.9/17.2m				16.0
18.0	16.9				15.0				13.7				18.0
20.0	16.4				14.6				13.3				20.0
22.0	16.0				14.2				12.8				22.0
24.0	15.5				13.7				12.4				24.0
26.0	15.0				13.3				12.0				26.0
28.0	14.6				12.9				11.6				28.0
30.0	14.1				12.5				11.2				30.0
32.0	13.6	12.7/33.2m			12.0				10.8				32.0
34.0	12.6	12.3			11.6	11.8/34.5m			10.4	10.6/35.7m			34.0
36.0	11.5	11.3			10.9	11.1			9.8	10.4			36.0
38.0	10.6	10.5			10.1	10.2			9.1	9.7			38.0
40.0	9.6	9.7			9.4	9.4			8.5	9.0			40.0
42.0	8.8	9.0			8.6	8.7			7.9	8.4			42.0
44.0	8.1	8.4			7.9	8.1			7.4	7.8			44.0
46.0	7.1	7.8			7.3	7.6			6.9	7.3			46.0
48.0	6.1/47.5m	7.2	6.9/49.7m		6.6	7.0			6.3	6.8			48.0
50.0		6.8	6.8		5.6	6.6	6.3/51.5m		5.9	6.4			50.0
52.0		6.4	6.4		5.3/50.5m	6.2	6.2		5.4	6.0	5.7/53.2m		52.0
54.0		6.0	6.0			5.8	5.8		4.9/53.4m	5.6	5.6		54.0
56.0		5.7	5.7			5.5	5.5			5.3	5.3		56.0
58.0		5.4/57.6m	5.4			5.2	5.2			5.0	5.0		58.0
60.0			5.2			5.0	5.0			4.8	4.8		60.0
62.0			5.0			4.9/60.5m	4.8			4.6	4.6		62.0
64.0			4.8	4.3/64.8m			4.6			4.3/63.5m	4.4		64.0
66.0			4.6	4.2			4.4	3.9/66.9m			4.2		66.0
68.0			4.4/67.2m	4.0			4.2	3.8			4.0		68.0
70.0				3.8			4.0	3.6			3.8		70.0
72.0				3.6			4.0/70.2m	3.4			3.6		72.0
74.0				3.4				3.2			3.5/73.1m		74.0
76.0				3.2				3.0					76.0
78.0				3.2/76.2m				2.8					78.0
80.0								2.7/79.2m					80.0

※表中の太線で囲まれた部分は、ブーム等の強度によって定められた値です。

▶タワー長さ **61.0m** (117.1tウエイト) ▲7200のみ

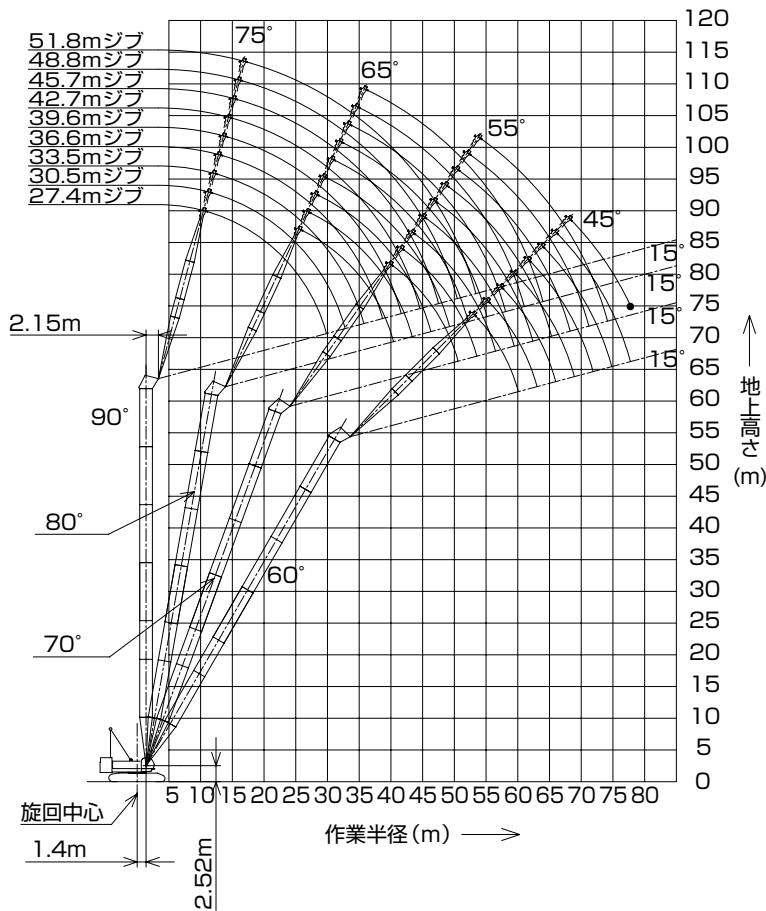

(単位:t)

タワー長さm	61.0												タワー長さm
ジブ長さm	27.4				30.5				33.5				ジブ長さm
タワー角度	90°	80°	70°	60°	90°	80°	70°	60°	90°	80°	70°	60°	タワー角度
作業半径 (m)	10.0	25.0/10.9m			25.0/11.7m								10.0
	12.0	25.0			25.0				25.0/12.5m				12.0
	14.0	25.0			25.0				25.0				14.0
	16.0	24.6			24.6				24.0				16.0
	18.0	23.7			23.7				23.0				18.0
	20.0	22.9			22.7				22.0				20.0
	22.0	21.5			21.5				21.0				22.0
	24.0	20.0			20.0				20.0				24.0
	26.0	18.3	18.6/26.0m		18.6	17.4/27.3m			18.8				26.0
	28.0	16.3	16.8		16.7	16.7			16.7	16.4/28.5m			28.0
	30.0	11.3/29.9m	15.2		15.1	15.1			15.3	15.1			30.0
	32.0		14.0		12.0	13.9			14.0	13.9			32.0
	34.0		12.8		10.6/32.8m	12.7			12.3	12.7			34.0
	36.0		11.8			11.7			9.4/35.8m	11.7			36.0
	38.0		11.1			11.0				11.0			38.0
	40.0		10.4	10.3/40.3m		10.3				10.2			40.0
	42.0		10.2/40.4m	9.7		9.5	9.6/42.0m		9.6	8.8/43.8m			42.0
	44.0			9.1		9.1	9.2/43.4m	9.0	8.9	8.8			44.0
	46.0			8.6		8.5			8.4	8.4			46.0
	48.0			8.2		8.0			8.4/46.3m	7.9			48.0
50.0			7.8		7.6				7.5			50.0	
52.0			7.7/50.6m	6.8/53.4m	7.3				7.1			52.0	
54.0				6.7		6.9/53.6m	6.4/55.5m		6.7			54.0	
56.0				6.4			6.3		6.4	5.7/57.7m		56.0	
58.0				6.1			6.0		6.3/56.5m	5.7		58.0	
60.0				5.8			5.7			5.5		60.0	
62.0				5.8/60.1m			5.4			5.2		62.0	
64.0							5.2/63.0m			5.0		64.0	
66.0										4.8		66.0	
68.0											4.8/66.0m	68.0	

※表中の太線で囲まれた部分は、ブーム等の強度によって定められた値です。

(単位:t)

タワー長さm	61.0												タワー長さm
ジブ長さm	36.6				39.6				42.7				ジブ長さm
タワー角度	90°	80°	70°	60°	90°	80°	70°	60°	90°	80°	70°	60°	タワー角度
12.0	23.9/13.3m												12.0
14.0	23.6				22.0/14.1m				20.0/14.9m				14.0
16.0	22.9				21.4				19.7				16.0
18.0	22.2				20.8				19.2				18.0
20.0	21.4				20.2				18.6				20.0
22.0	20.7				19.6				18.1				22.0
24.0	19.9				19.0				17.5				24.0
26.0	18.8				18.3				17.0				26.0
28.0	16.8	15.2/29.8m			16.8				16.5				28.0
30.0	15.2	15.0			15.2	14.3/31.1m			15.2				30.0
32.0	14.0	13.8			14.0	13.7			14.0	13.5/32.4m			32.0
34.0	12.8	12.6			12.8	12.5			12.8	12.4			34.0
36.0	11.5	11.6			11.8	11.5			11.8	11.4			36.0
38.0	9.5	10.9			10.7	10.8			10.8	10.6			38.0
40.0	8.9/38.7m	10.1			9.5	10.0			9.8	9.8			40.0
42.0		9.5			7.9/41.7m	9.4			8.9	9.2			42.0
44.0		8.9	8.4/45.5m			8.8			7.4	8.6			44.0
46.0		8.4	8.3			8.2	7.8/47.3m		6.9/44.6m	8.0			46.0
48.0		7.8	7.8			7.6	7.6			7.4	7.2/49.0m		48.0
50.0		7.5/49.3m	7.4			7.2	7.2			7.0	7.0		50.0
52.0			7.0			6.8	6.8			6.6	6.6		52.0
54.0			6.6			6.8/52.2m	6.4			6.2	6.2		54.0
56.0			6.3				6.1			5.9/55.2m	5.9		56.0
58.0			6.0	5.3/59.8m			5.8				5.6		58.0
60.0			5.8/59.4m	5.3			5.6				5.4		60.0
62.0				5.1			5.4	4.9/62.0m			5.2		62.0
64.0				4.9			5.3/62.4m	4.7			5.0	4.0/64.1m	64.0
66.0				4.7				4.5			4.9/65.3m	4.0	66.0
68.0				4.4				4.2				3.8	68.0
70.0				4.3/68.9m				3.9				3.6	70.0
72.0								3.6				3.4	72.0
74.0								3.6/71.9m				3.2	74.0
76.0												3.1/74.8m	76.0

※表中の太線で囲まれた部分は、ブーム等の強度によって定められた値です。

(単位:t)

タワー長さm	61.0												タワー長さm
ジブ長さm	45.7				48.8				51.8				ジブ長さm
タワー角度	90°	80°	70°	60°	90°	80°	70°	60°	90°	80°	70°	タワー角度	
14.0	17.4/15.7m												14.0
16.0	17.4				15.4/16.5m				13.9/17.2m				16.0
18.0	16.9				15.0				13.7				18.0
20.0	16.4				14.6				13.3				20.0
22.0	16.0				14.2				12.8				22.0
24.0	15.5				13.7				12.4				24.0
26.0	15.0				13.3				12.0				26.0
28.0	14.6				12.9				11.6				28.0
30.0	14.1				12.5				11.2				30.0
32.0	13.6	12.6/33.7m			12.0				10.8				32.0
34.0	12.6	12.3			11.6	11.4/35.0m			10.4				34.0
36.0	11.5	11.3			10.8	11.0			9.8	9.7/36.3m			36.0
38.0	10.4	10.5			9.9	10.1			9.1	9.3			38.0
40.0	9.5	9.7			9.3	9.3			8.5	8.7			40.0
42.0	8.7	9.0			8.5	8.6			7.9	8.2			42.0
44.0	8.1	8.4			7.8	8.0			7.4	7.6			44.0
46.0	7.2	7.8			7.3	7.5			6.9	7.1			46.0
48.0	6.2/47.5m	7.2			6.6	6.9			6.3	6.6			48.0
50.0		6.8	6.7/50.8m		5.6	6.5			5.8	6.2			50.0
52.0		6.4	6.4		5.3/50.5m	6.1	6.0/52.5m		5.3	5.8			52.0
54.0		6.0	6.0			5.7	5.7		4.9/53.4m	5.4	5.3/54.2m		54.0
56.0		5.7	5.7			5.4	5.4			5.1	5.1		56.0
58.0		5.4	5.4			5.1	5.1			4.8	4.8		58.0
60.0		5.4/58.1m	5.2			4.9	4.9			4.6	4.6		60.0
62.0			5.0			4.7/61.0m	4.7			4.4	4.4		62.0
64.0			4.8				4.5			4.1/64.0m	4.2		64.0
66.0			4.6	3.7/66.3m			4.3				4.0		66.0
68.0			4.3	3.5			4.1				3.8		68.0
70.0			4.3/68.3m	3.3			3.9	3.1/70.0m			3.6		70.0
72.0				3.1			3.8/71.2m	2.9			3.4		72.0
74.0				2.9				2.7			3.2		74.0
76.0				2.7				2.5			3.2/74.2m		76.0
78.0				2.5/77.8m				2.3/78.0m					78.0

※表中の太線で囲まれた部分は、ブーム等の強度によって定められた値です。

▶タワー長さ **64.1m** (117.1tウエイト) ▲7200のみ

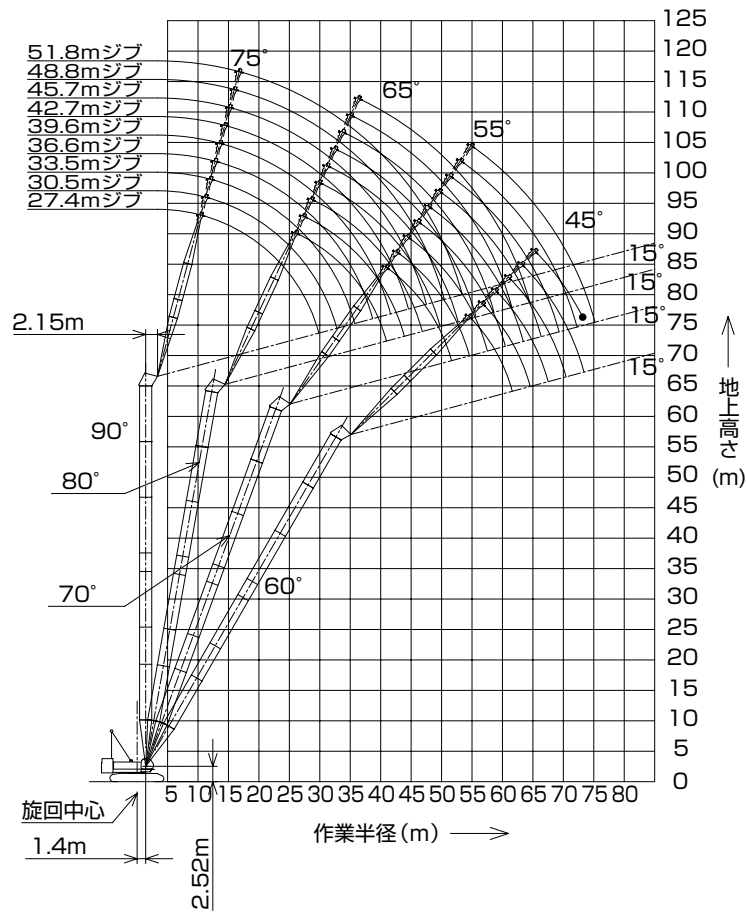

(単位:t)

タワー長さm	64.1												タワー長さm
ジブ長さm	27.4				30.5				33.5				ジブ長さm
タワー角度	90°	80°	70°	60°	90°	80°	70°	60°	90°	80°	70°	60°	タワー角度
作業半径 (m)	10.0	25.0/10.9m			25.0/11.7m								10.0
	12.0	25.0			25.0				24.8/12.5m				12.0
	14.0	24.3			24.3				24.3				14.0
	16.0	23.6			23.6				23.6				16.0
	18.0	22.9			22.9				22.9				18.0
	20.0	22.2			22.2				22.0				20.0
	22.0	21.5			21.5				21.0				22.0
	24.0	20.0			20.0				20.0				24.0
	26.0	18.3	18.3/26.5m		18.6	15.9/27.8m			18.8				26.0
	28.0	16.3	16.8		16.7	16.7			16.7	15.9/29.1m			28.0
	30.0	11.3/29.9m	15.2		15.1	15.1			15.3	15.1			30.0
	32.0		14.0		12.0	13.9			14.0	13.9			32.0
	34.0		12.8		10.6/32.8m	12.7			12.3	12.7			34.0
	36.0		11.8			11.7			9.4/35.8m	11.7			36.0
	38.0		11.1			11.0				11.0			38.0
	40.0		10.4	9.9/41.3m		10.3				10.2			40.0
	42.0		10.0/41.0m	9.7		9.5	9.3/43.1m			9.6			42.0
	44.0			9.1		9.0/43.9m	9.0			8.9	8.7/44.8m		44.0
	46.0			8.6			8.5			8.4	8.4		46.0
	48.0			8.2			8.0			8.2/46.9m	7.9		48.0
50.0			7.8			7.6				7.5		50.0	
52.0			7.4/51.7m			7.3				7.1		52.0	
54.0				6.0/54.9m		6.9				6.7		54.0	
56.0				5.9		6.7/54.6m	5.4/57.1m			6.4		56.0	
58.0				5.7			5.3			6.2/57.5m	4.9/59.2m	58.0	
60.0				5.5			5.1				4.8	60.0	
62.0				5.3/61.6m			4.9				4.6	62.0	
64.0							4.7				4.4	64.0	
66.0							4.6/64.6m				4.2	66.0	
68.0											4.0/67.5m	68.0	

※表中の太線で囲まれた部分は、ブーム等の強度によって定められた値です。

(単位:t)

タワー長さm	64.1												タワー長さm
ジブ長さm	36.6				39.6				42.7				ジブ長さm
タワー角度	90°	80°	70°	60°	90°	80°	70°	60°	90°	80°	70°	60°	タワー角度
12.0	23.9/13.3m												12.0
14.0	23.6				22.0/14.1m				20.0/14.9m				14.0
16.0	22.9				21.4				19.7				16.0
18.0	22.2				20.8				19.2				18.0
20.0	21.4				20.2				18.6				20.0
22.0	20.7				19.6				18.1				22.0
24.0	19.9				19.0				17.5				24.0
26.0	18.8				18.3				17.0				26.0
28.0	16.8				16.8				16.5				28.0
30.0	15.2	14.9/30.4m			15.2	13.9/31.7m			15.2				30.0
32.0	14.0	13.8			14.0	13.7			14.0	13.3/32.9m			32.0
34.0	12.8	12.6			12.8	12.5			12.8	12.4			34.0
36.0	11.5	11.6			11.8	11.5			11.8	11.4			36.0
38.0	9.5	10.9			10.7	10.8			10.8	10.6			38.0
40.0	8.9/38.7m	10.1			9.5	10.0			9.7	9.8			40.0
42.0		9.5			7.9/41.7m	9.4			8.8	9.2			42.0
44.0		8.9				8.8			7.4	8.6			44.0
46.0		8.4	8.1/46.5m			8.2			6.9/44.6m	8.0			46.0
48.0		7.8	7.8			7.6	7.6/48.3m			7.4			48.0
50.0		7.4/49.8m	7.4			7.2	7.2			7.0	7.0/50.0m		50.0
52.0			7.0			6.7	6.8			6.6	6.6		52.0
54.0			6.6			6.6/52.7m	6.4			6.1	6.2		54.0
56.0			6.3				6.1			5.8/55.7m	5.9		56.0
58.0			6.0				5.8				5.6		58.0
60.0			5.7	4.5/61.4m			5.6				5.4		60.0
62.0			5.6/60.5m	4.4			5.4	4.0/63.5m			5.2		62.0
64.0				4.2			5.3/63.4m	4.0			5.0		64.0
66.0				4.0				3.8			4.8	3.4/66.0m	66.0
68.0				3.8				3.6			4.7/66.4m	3.4	68.0
70.0				3.6				3.4				3.2	70.0
72.0				3.5/70.5m				3.2				3.0	72.0
74.0								3.0/73.4m				2.8/74.0m	74.0

※表中の太線で囲まれた部分は、ブーム等の強度によって定められた値です。

(単位:t)

タワー長さm	64.1									タワー長さm
ジブ長さm	45.7			48.8			51.8			ジブ長さm
タワー角度	90°	80°	70°	90°	80°	70°	90°	80°	70°	タワー角度
14.0	17.4/15.7m									14.0
16.0	17.4			15.4/16.5m			13.9/17.2m			16.0
18.0	16.9			15.0			13.7			18.0
20.0	16.4			14.6			13.3			20.0
22.0	16.0			14.2			12.8			22.0
24.0	15.5			13.7			12.4			24.0
26.0	15.0			13.3			11.9			26.0
28.0	14.6			12.9			11.5			28.0
30.0	14.1			12.5			11.1			30.0
32.0	13.6			12.0			10.8			32.0
34.0	12.6	12.3/34.2m		11.6	11.4/35.5m		10.4			34.0
36.0	11.5	11.3		10.8	11.0		9.8	9.2/36.8m		36.0
38.0	10.4	10.5		9.9	10.1		9.1	9.0		38.0
40.0	9.5	9.7		9.3	9.3		8.5	8.4		40.0
42.0	8.7	9.0		8.5	8.6		7.9	7.9		42.0
44.0	7.9	8.4		7.8	8.0		7.4	7.3		44.0
46.0	7.1	7.8		7.1	7.5		6.8	6.8		46.0
48.0	6.2/47.5m	7.2		6.4	6.9		6.2	6.3		48.0
50.0		6.8	6.4/51.8m	5.6	6.5		5.6	5.9		50.0
52.0		6.4	6.4	5.3/50.5m	6.1	5.8/53.5m	5.0	5.5		52.0
54.0		6.0	6.0		5.7	5.7	4.5/53.4m	5.1	4.9/55.3m	54.0
56.0		5.7	5.7		5.4	5.4		4.8	4.8	56.0
58.0		5.4	5.4		5.1	5.1		4.5	4.5	58.0
60.0		5.3/58.6m	5.2		4.9	4.9		4.3	4.3	60.0
62.0			5.0		4.7/61.6m	4.7		4.1	4.1	62.0
64.0			4.8			4.5		3.8	3.9	64.0
66.0			4.6			4.3		3.7/64.5m	3.7	66.0
68.0			4.4			4.1			3.5	68.0
70.0			4.3/69.3m			3.9			3.3	70.0
72.0						3.8			3.1	72.0
74.0						3.7/72.3m			3.0	74.0
76.0									2.9/75.2m	76.0

※表中の太線で囲まれた部分は、ブーム等の強度によって定められた値です。

アタッチメント

▶ クラムセル

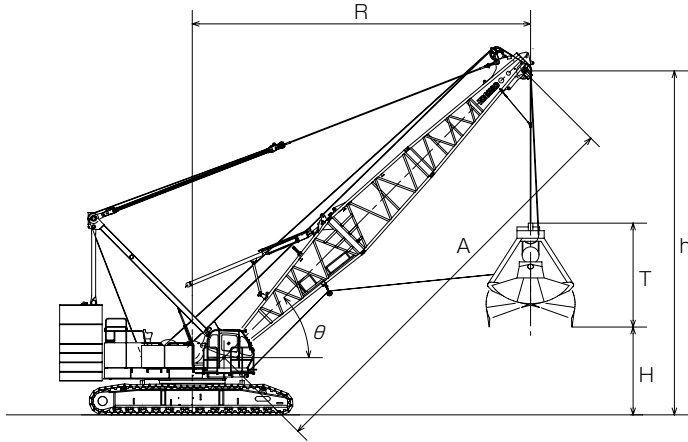

バケット開口時高さ	バケット容量	2.0m ³	T	3.9m
		2.5m ³		4.3m
		3.0m ³		4.5m
		4.0m ³		4.7m

〈注〉

- ・バケットの単体質量は7tを越えてはいけません。
- ・掘削物に応じて、次式より最適なバケットをお選びください。
 $\text{バケット容量 (m}^3\text{)} \times \text{掘削物比重 (t/m}^3\text{)} + \text{バケット質量 (t)} \leq \text{定格総荷重}$
 (例) バケット容量3.0m³、掘削物砂(比重約1.5)、バケット質量5.5tの場合
 $(\text{バケット容量}) \times (\text{掘削物比重}) + (\text{バケット質量}) \leq (\text{定格総荷重})$
 $3.0\text{m}^3 \times 1.5 + 5.5\text{t} = 10.0\text{t}$

ブーム長さ	m	A	18.3										21.3										
ブーム角度	度	θ	38°	43°	48°	52°	56°	60°	63°	67°	70°	36°	40°	44°	48°	51°	55°	58°	61°	64°	67°	70°	
作業半径	m	R	16.0	15.0	14.0	13.0	12.0	11.0	10.0	9.0	8.0	19.0	18.0	17.0	16.0	15.0	14.0	13.0	12.0	11.0	10.0	9.0	
開口地上高さ m	バケット容量	H	2.0m ³	6.9	8.2	9.2	10.1	10.8	11.5	12.1	12.6	13.0	8.0	9.3	10.5	11.5	12.4	13.1	13.8	14.4	15.0	15.5	15.9
			2.5m ³	6.5	7.8	8.8	9.7	10.4	11.1	11.7	12.2	12.6	7.6	8.9	10.1	11.1	12.0	12.7	13.4	14.0	14.6	15.1	15.5
			3.0m ³	6.3	7.6	8.6	9.5	10.2	10.9	11.5	12.0	12.4	7.4	8.7	9.9	10.9	11.8	12.5	13.2	13.8	14.4	14.9	15.3
			4.0m ³	6.1	7.4	8.4	9.3	10.0	10.7	11.3	11.8	12.2	7.2	8.5	9.7	10.7	11.6	12.3	13.0	13.6	14.2	14.7	15.1
ブームポイント高さ	m	h	13.5	14.8	15.8	16.7	17.4	18.1	18.7	19.2	19.6	14.6	15.9	17.1	18.1	19.0	19.7	20.4	21.0	21.6	22.1	22.5	
定格総荷重	t		12.5										12.5										

ブーム長さ	m	A	24.4													
ブーム角度	度	θ	33°	37°	41°	45°	48°	51°	54°	57°	60°	63°	65°	68°	70°	
作業半径	m	R	22.0	21.0	20.0	19.0	18.0	17.0	16.0	15.0	14.0	13.0	12.0	11.0	10.0	
開口地上高さ m	バケット容量	H	2.0m ³	9.0	10.4	11.7	12.8	13.8	14.7	15.5	16.2	16.8	17.4	17.9	18.3	18.7
			2.5m ³	8.6	10.0	11.3	12.4	13.4	14.3	15.1	15.8	16.4	17.0	17.5	17.9	18.3
			3.0m ³	8.4	9.8	11.1	12.2	13.2	14.1	14.9	15.6	16.2	16.8	17.3	17.7	18.1
			4.0m ³	8.2	9.6	10.9	12.0	13.0	13.9	14.7	15.4	16.0	16.6	17.1	17.5	17.9
ブームポイント高さ	m	h	15.6	17.0	18.3	19.4	20.4	21.3	22.1	22.8	23.4	24.0	24.5	24.9	25.3	
定格総荷重	t		12.5													

ブーム長さ	m	A	27.4														
ブーム角度	度	θ	35°	39°	42°	45°	48°	51°	54°	56°	59°	61°	63°	66°	68°	70°	
作業半径	m	R	24.0	23.0	22.0	21.0	20.0	19.0	18.0	17.0	16.0	15.0	14.0	13.0	12.0	11.0	
開口地上高さ m	バケット容量	H	2.0m ³	11.5	12.8	14.0	15.1	16.1	17.0	17.8	18.5	19.2	19.8	20.3	20.8	21.2	21.6
			2.5m ³	11.1	12.4	13.6	14.7	15.7	16.6	17.4	18.1	18.8	19.4	19.9	20.4	20.8	21.2
			3.0m ³	10.9	12.2	13.4	14.5	15.5	16.4	17.2	17.9	18.6	19.2	19.7	20.2	20.6	21.0
			4.0m ³	10.7	12.0	13.2	14.3	15.3	16.2	17.0	17.7	18.4	19.0	19.5	20.0	20.4	20.8
ブームポイント高さ	m	h	18.1	19.4	20.6	21.7	22.7	23.6	24.4	25.1	25.8	26.4	26.9	27.4	27.8	28.2	
定格総荷重	t		12.5														

ブーム長さ	m	A	30.5																
ブーム角度	度	θ	34°	37°	40°	43°	46°	48°	51°	53°	55°	58°	60°	62°	64°	66°	68°	70°	
作業半径	m	R	27.0	26.0	25.0	24.0	23.0	22.0	21.0	20.0	19.0	18.0	17.0	16.0	15.0	14.0	13.0	12.0	
開口地上高さ m	バケット容量	H	2.0m ³	12.5	13.9	15.2	16.4	17.4	18.4	19.3	20.1	20.8	21.5	22.1	22.7	23.2	23.7	24.1	24.5
			2.5m ³	12.1	13.5	14.8	16.0	17.0	18.0	18.9	19.7	20.4	21.1	21.7	22.3	22.8	23.3	23.7	24.1
			3.0m ³	11.9	13.3	14.6	15.8	16.8	17.8	18.7	19.5	20.2	20.9	21.5	22.1	22.6	23.1	23.5	23.9
			4.0m ³	11.7	13.1	14.4	15.6	16.6	17.6	18.5	19.3	20.0	20.7	21.3	21.9	22.4	22.9	23.3	23.7
ブームポイント高さ	m	h	19.1	20.5	21.8	23.0	24.0	25.0	25.9	26.7	27.4	28.1	28.7	29.3	29.8	30.3	30.7	31.1	
定格総荷重	t		12.5																

ブーム長さ	m	A	33.5																	
ブーム角度	度	θ	35°	38°	41°	43°	46°	48°	51°	53°	55°	57°	59°	61°	63°	65°	67°	69°	70°	
作業半径	m	R	29.0	28.0	27.0	26.0	25.0	24.0	23.0	22.0	21.0	20.0	19.0	18.0	17.0	16.0	15.0	14.0	13.0	
開口地上高さ m	バケット容量	H	2.0m ³	15.0	16.3	17.6	18.7	19.7	20.7	21.6	22.4	23.1	23.8	24.5	25.1	25.6	26.1	26.6	27.0	27.4
			2.5m ³	14.6	15.9	17.2	18.3	19.3	20.3	21.2	22.0	22.7	23.4	24.1	24.7	25.2	25.7	26.2	26.6	27.0
			3.0m ³	14.4	15.7	17.0	18.1	19.1	20.1	21.0	21.8	22.5	23.2	23.9	24.5	25.0	25.5	26.0	26.4	26.8
			4.0m ³	14.2	15.5	16.8	17.9	18.9	19.9	20.8	21.6	22.3	23.0	23.7	24.3	24.8	25.3	25.8	26.2	26.6
ブームポイント高さ	m	h	21.6	22.9	24.2	25.3	26.3	27.3	28.2	29.0	29.7	30.4	31.1	31.7	32.2	32.7	33.2	33.6	34.0	
定格総荷重	t		11.7	12.0	12.3														12.5	

台船搭載

▶ カウンタウエイト75.1t(6枚) 装着(カーボディウエイトなし)

(単位:t)

ブーム長さ (m) 作業半径(m)	18.3	21.3	24.4	27.4	30.5	33.5	36.6	39.6	42.7	45.7	48.8	51.8	54.9	ブーム長さ (m) 作業半径(m)
6.0	130.0	6.6m/114.0												6.0
7.0	109.0	107.2	7.3m/103.0											7.0
8.0	93.5	93.1	92.7	92.5	8.7m/82.5									8.0
9.0	82.6	82.2	81.8	81.4	81.1	9.4m/75.0								9.0
10.0	73.8	73.4	73.0	72.7	72.4	72.1	10.1m/67.5	10.7m/62	11.4m/56.5					10.0
12.0	58.4	60.3	59.9	59.6	59.2	58.9	58.6	58.2	55.6	12.1m/52.0	12.8m/48	13.5m/43.8		12.0
14.0	47.1	48.9	49.1	49.8	49.9	49.6	49.3	49.0	48.7	48.5	46.2	43.2	14.2m/40.5	14.0
16.0	38.1	40.1	40.5	41.4	42.1	42.6	42.3	42.0	41.7	41.4	40.9	40.8	38.7	16.0
18.0	17.4m/30.2	33.4	34.1	35.0	35.5	36.2	36.7	36.4	36.2	35.9	35.4	35.2	35.0	18.0
20.0		26.6	29.2	29.9	30.5	31.0	31.5	31.5	31.3	31.2	31.0	30.8	30.5	20.0
22.0		20.1m/26.1	25.3	25.9	26.5	27.0	27.4	27.6	27.4	27.2	27.0	26.8	26.6	22.0
24.0			22.7m/23.1	22.8	23.3	23.7	24.0	24.2	24.1	24.0	23.8	23.6	23.4	24.0
26.0				25.4m/20.6	20.6	21.1	21.4	21.5	21.6	21.4	21.2	21.0	20.7	26.0
28.0					18.4	18.7	19.0	19.2	19.4	19.2	19.0	18.7	18.5	28.0
30.0						16.8	17.1	17.3	17.5	17.3	17.1	16.9	16.6	30.0
32.0						30.6m/16.2	15.5	15.6	16.0	15.8	15.5	15.3	15.0	32.0
34.0							33.3m/14.5	14.2	14.5	14.3	14.1	13.9	13.7	34.0
36.0								35.9m/12.9	13.4	13.2	12.9	12.6	12.4	36.0
38.0									12.4	12.2	11.9	11.6	11.3	38.0
40.0									38.6m/12.1	11.2	10.9	10.6	10.4	40.0
42.0										41.2m/10.7	10.1	9.8	9.6	42.0
44.0											43.8m/9.4	9.0	8.8	44.0
46.0												8.4	8.1	46.0
48.0												46.5m/8.3	7.5	48.0
50.0													49.1m/7.2	50.0

〈注〉

- ①作業半径とはクレーンの旋回中心よりつり上げ荷重の重心までの水平距離を意味します。
- ②定格総荷重は、フックブロック、玉掛用ワイヤロープ等のつり具の重量を含んだ値です。
- ③作業時のクレーン部の傾斜角度は、水平面に対してクレーン前後方向で3°以内、クレーン左右方向で1.5°以内となるようにして下さい。定格総荷重はこの条件において設定しています。
- ④上表能力はクローラを固縛した時の能力です。

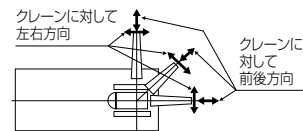

▶ クラムセル

(単位:t)

ブーム長さ (m) 作業半径(m)	18.3	21.3	24.4	27.4	30.5	33.5	ブーム長さ (m) 作業半径(m)
9.0	12.5						9.0
10.0	12.5	12.5					10.0
11.0	12.5	12.5	12.5				11.0
12.0	12.5	12.5	12.5	12.5			12.0
13.0	12.5	12.5	12.5	12.5	12.5		13.0
14.0	12.5	12.5	12.5	12.5	12.5	10.0	14.0
15.0	12.5	12.5	12.5	12.5	12.5	10.0	15.0
16.0	12.5	12.5	12.5	12.5	12.5	10.0	16.0
17.0		12.5	12.5	12.5	12.5	10.0	17.0
18.0		12.5	12.5	12.5	12.5	10.0	18.0
19.0		12.5	12.5	12.5	12.5	10.0	19.0
20.0			12.5	12.5	12.5	10.0	20.0
21.0			12.5	12.5	12.5	10.0	21.0
22.0			12.5	12.5	12.5	10.0	22.0
23.0				12.5	12.5	10.0	23.0
24.0				12.5	12.5	10.0	24.0
25.0					12.5	10.0	25.0
26.0					12.5	10.0	26.0

〈注〉

- ①バケットの単体質量は7tを超えてはいけません。
- ②バケットと掘削物の合計質量が定格総荷重を超えてはいけません。
- ③作業半径とは荷重状態におけるクレーンの旋回中心よりバケット重心までの水平距離を意味します。
- ④旋回時にブーム横引き荷重が作用するような急加速・急減速運転、旋回投げ捨ておよび斜め引き掘削等は行わないで下さい。
- ⑤作業時のクレーン部の傾斜角度は、水平面に対してクレーン前後方向で3°以内、クレーン左右方向で1.5°以内となるようにして下さい。定格総荷重はこの条件において設定しています。
- ⑥上表能力はクローラを固縛した時の能力です。

▶分解時の寸法・質量

- 記載の数値は参考値です。
- 一般公道での輸送に際しては関係法規を遵守してください。

■本体

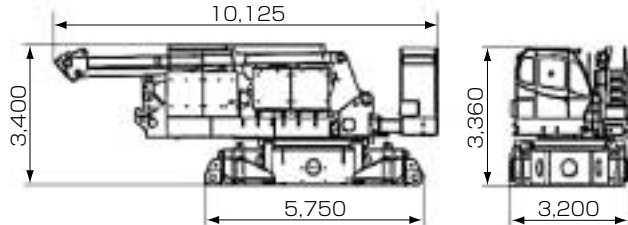
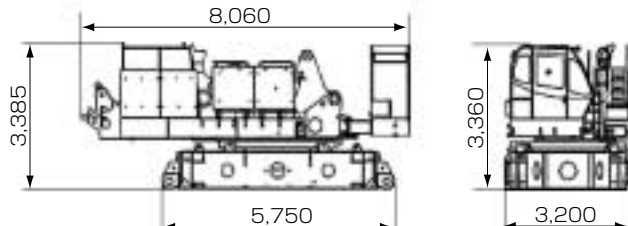
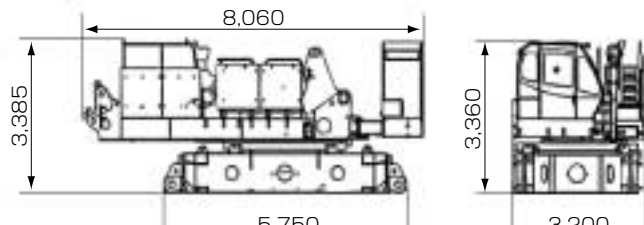
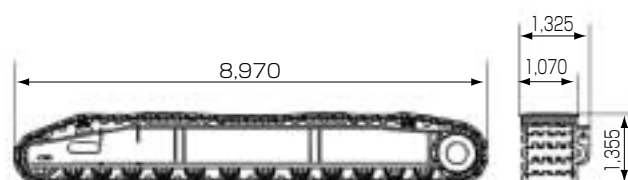
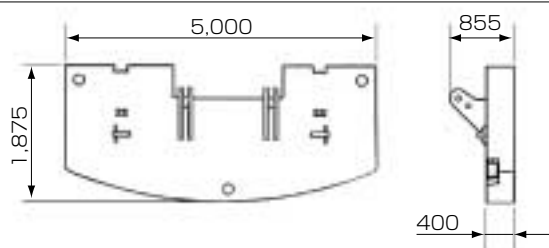
名称	寸法 (幅×高さ×長さ) mm	質量 kg
上部本体 ・カーボディ、ガントリ、 トランスリフタを含む ・下部スレダ、 ブーム起伏ロープ、 主巻ロープ無し		37,300
上部本体 ・カーボディを含む ・トランスリフタ、 ガントリ、 ブーム起伏ロープ、 主巻ロープ、 ブーム起伏ドラム無し		31,100
上部本体 ・カーボディを含む ・トランスリフタ、ガントリ、 ブーム起伏ロープ、 主巻ドラム、補巻ドラム、 ブーム起伏ドラム無し		27,600
クローラ		20,000
トランスリフタ	400×1,390×1,145	395
カウンタウエイト (A)		13,500
カウンタウエイト (B)	5,000×530×1,875	13,200
カウンタウエイト (C)	5,000×530×1,875	13,200
カウンタウエイト (D)	5,000×530×1,875	13,200
カウンタウエイト (E/E')	1,820×980×1,700	11,000×2
カウンタウエイト (F/F')	1,820×980×1,700	11,000×2
カーボディウエイト	1,745×1,760×1,045	10,000×2

■アタッチメント（ガイラインの質量は含まれていません）

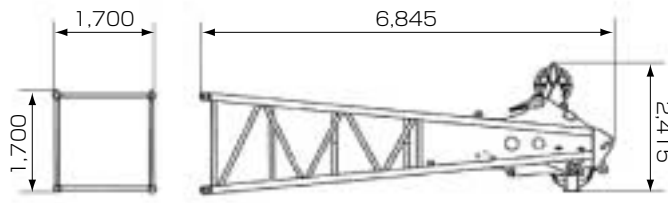
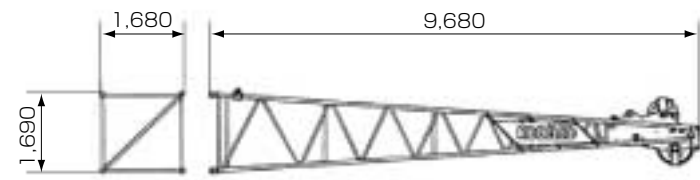
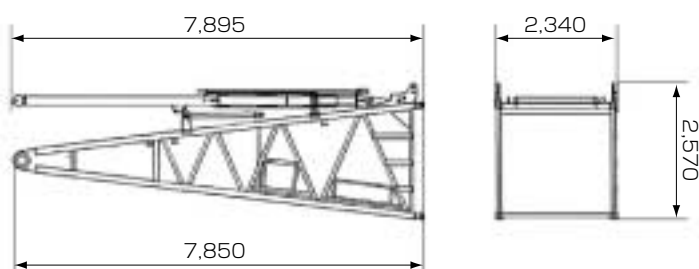
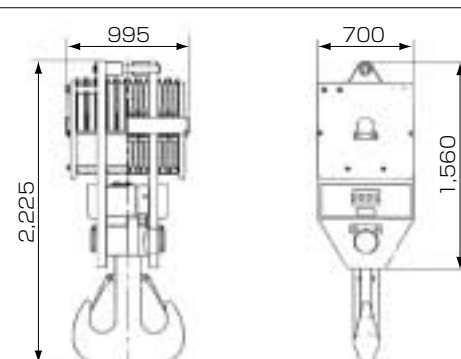
名称	寸法（幅×高さ×長さ）mm	質量 kg
上部ブーム		2,910
ロング上部ブーム 兼 上部タワージブ		1,120
下部ブーム (バックストップ付)		4,180
3.0m中間ブーム	2,340×2,225×3,175	740
6.1m中間ブーム	2,340×2,225×6,225	1,210
9.1m中間ブーム	2,340×2,225×9,270	1,680
中間テーパーブーム	2,340×2,360×4,700	1,160
9.1mタワー専用中間ブーム	2,340×2,880×9,270	2,200
上部スプレッド	250×890×2,410	670
下部スプレッド	290×760×1,500	400
タワーキャップ	2,295×2,365×5,740	2,310
3.0m中間タワージブ	1,690×1,670×3,160	320
6.1m中間タワージブ	1,690×1,670×6,210	530
9.1m中間タワージブ	1,690×1,670×9,260	740
下部タワージブ	2,390×1,700×9,605	1,710
タワーストラット	2,430×1,150×7,165	2,190
タワージブ用上部スプレッド	335×765×1,020	260
タワージブ用下部スプレッド	705×1,090×2,335	490
ガントリ	1,710×7,715×785	2,830
200tフック		2,800
150tフック	700×2,665×715	2,300
100tフック	700×2,025×555	1,800
65tフック	700×1,815×385	1,200
35tフック	700×1,575×365	900
ボールフック	φ380×1,200	450

▶標準装備品

●上下部本体
φ28mmウインチ(フリーフォールなし、主巻/補巻)【7200】
φ28mmウインチ(フリーフォール付、主巻/補巻)【7200FS】
カウンタウエイト117.1t(13.5t+13.2t×3+11t×4+10t×2t)
1,070mm幅シュー
136AH/5HRバッテリー
トランスリフタ
ガントリ起伏シリンダ
電動ハンドスロットル
ブーム速度可変コントローラ
主補速度可変コントローラ
旋回中立フリー/プレーキ切替システム
運転席サイドデッキ(手すり付):幅500mm×長さ2,600mm
左側サイドキャットウォーク(手すり付)
左ガード前面昇降ステップ
クローラ昇降ステップ
アンチスリップシート(ガード上面、カウンタウエイト上面)
ブームコネクタピンホルダー
ケーブルローラ(ブーム)
上部スプレッド格納ガイド
ジブ上部スプレッドスライドレール(タワー仕様)
標準工具一式
前照灯×2
バックミラー×2
ドラムミラー
ワンウェイコール
水準器(カーボディ)
●運転室
エアコン
ラゲッジトレイ
カップキーパ
ラジオ(FM/AM)
灰皿

シガーライタ
間欠式ワイパ&ウインドウォッシャ(天窓/前面/前面下窓)
サンバイザ
天井ブラインド
グリーンガラス
フロアマット(布製)
フットレスト
靴置きトレイ
●安全装置
過負荷防止装置(ブーム巻下緩停止機能付)
過負荷防止装置解除防止キー
過巻防止装置解除防止キー
液晶マルチディスプレイ
第2過巻防止装置(ブーム角度極限停止機能付)
ブーム過巻自動停止装置(緩停止機能付)
フック過巻自動停止装置
ブームバックストップ
乗降遮断式レバーロック
走行レバーロック
手動式ドラムパウルロック(主巻/補巻)
手動式ドラムパウルロック(ブーム起伏)
中立時ネガプレーキ(主巻/補巻/ブーム起伏/走行)
組立分解モードスイッチ
タワージブ格納緩停止機能
旋回中立フリー/プレーキ切替表示灯
旋回中立フリー/プレーキ切替スイッチ(ロック機構付)
油圧安全弁(主巻/補巻/ブーム起伏/走行)
ホーン
マルチボイスアラーム:過巻/過負荷
旋回プレーキロック
旋回ロック(全周4ヶ所)
旋回フラッシュ/ブザー

▶オプション装備品

トラベルキット
カウンタウエイトおよびクローラつり用ワイヤロープ
自立用敷板
リーピングウインチ:φ8×260m
フットアクセル:case1-右側、case2-左右両側
ブーム起伏ペダル:右側
ドラム回転計(主巻/補巻)
水準器(キャブ内)
キャブ上面ガード
アンダーカバー(右デッキ)
ブーム背面足場
ブーム背面全長足場(アルミ製)
ブーム上面ガイケーブル格納ブラケット
ブーム上面格納式手すり(スタンションバー)
ブームネスティング装置
左ガード上面手すり
定格総荷重表看板:下部ブーム腹面

ブーム看板(上部ブーム用、中間ブーム用)
後方確認カメラ&モニタ(カラー)
主・補ドラム確認カメラ&モニタ(カラー)
ブームドラム確認カメラ&モニタ(カラー)
過負荷外部表示灯(角型3色灯)
警報付風速計(クレーン用)
航空障害灯(点灯式)
外部音声アラーム:走行/旋回
上部ブーム腹面保護材
電動式燃料給油ポンプ
消火器
扇風機
揚程計
振り式角度計
ブーム梯子
カウンタウエイト75.1t仕様(カウンタウエイト検出装置)

Handwriting practice lines consisting of 28 horizontal dashed lines.



Handwriting practice lines consisting of 28 horizontal dashed lines.



感じています、新鮮!

小さな風。きっと最初はそこから始まる。
その風が共鳴しあい大きなニーズに成長する。
私たちは小さな風に耳を澄ます、感じとる。
人にもっと優しい技術の道を切り拓くために。
新しさと提案に満ちたマシンづくりを。
新風を感じ、帆いっぱい捉え、また新たな旋風を呼ぶ。
マシンと人間の新しい関係が生まれる。

“Feelin' Fresh!” は、何よりお客さまの現場を重視する
「ユーザー現場主義」の姿勢を貫くことを誓う
私たちのコーポレート・メッセージです。

つり上げ荷重5t以上の移動式クレーン運転には「移動式クレーン運転士免許証」、クラムセル作業には「車両系建設機械（整地ほか）運転技能講習修了証」、基礎工事には「車両系建設機械（基礎用）運転技能講習修了証」がそれぞれ必要です。

コベルコクレーン株式会社

www.kobelco-cranes.com

東京本社 / 〒141-8626 東京都品川区東五反田2-17-1 ☎03-5789-2130

北海道 ☎011-788-2386・宮城 ☎0223-24-1482・東京 ☎03-5789-2125

市川 ☎047-328-4311・北陸 ☎076-682-6300・東海 ☎052-603-1205

近畿 ☎06-6414-2103・中国 ☎082-810-3880・九州 ☎092-503-3329

■お問い合わせは……